

**PHILIPPINE BIDDING DOCUMENTS**

**Procurement of  
GOODS**

Government of the Republic of the Philippines

**Procurement of Materials for the Supply, Delivery, Installation,  
Testing and Commissioning of Electro-Mechanical Equipment for  
the New Pumping Station at Brgy. Tiguman, Digos City**

**Sixth Edition  
July 2020**

# Preface

These Philippine Bidding Documents (PBDs) for the procurement of Goods through Competitive Bidding have been prepared by the Government of the Philippines for use by any branch, constitutional commission or office, agency, department, bureau, office, or instrumentality of the Government of the Philippines, National Government Agencies, including Government-Owned and/or Controlled Corporations, Government Financing Institutions, State Universities and Colleges, and Local Government Unit. The procedures and practices presented in this document have been developed through broad experience, and are for mandatory use in projects that are financed in whole or in part by the Government of the Philippines or any foreign government/foreign or international financing institution in accordance with the provisions of the 2016 revised Implementing Rules and Regulations of Republic Act No. 9184.

The Bidding Documents shall clearly and adequately define, among others: (i) the objectives, scope, and expected outputs and/or results of the proposed contract or Framework Agreement, as the case may be; (ii) the eligibility requirements of Bidders; (iii) the expected contract or Framework Agreement duration, the estimated quantity in the case of procurement of goods, delivery schedule and/or time frame; and (iv) the obligations, duties, and/or functions of the winning bidder.

Care should be taken to check the relevance of the provisions of the PBDs against the requirements of the specific Goods to be procured. If duplication of a subject is inevitable in other sections of the document prepared by the Procuring Entity, care must be exercised to avoid contradictions between clauses dealing with the same matter.

Moreover, each section is prepared with notes intended only as information for the Procuring Entity or the person drafting the Bidding Documents. They shall not be included in the final documents. The following general directions should be observed when using the documents:

- a. All the documents listed in the Table of Contents are normally required for the procurement of Goods. However, they should be adapted as necessary to the circumstances of the particular Procurement Project.
- b. Specific details, such as the “*name of the Procuring Entity*” and “*address for bid submission*,” should be furnished in the Instructions to Bidders, Bid Data Sheet, and Special Conditions of Contract. The final documents should contain neither blank spaces nor options.
- c. This Preface and the footnotes or notes in italics included in the Invitation to Bid, Bid Data Sheet, General Conditions of Contract, Special Conditions of Contract, Schedule of Requirements, and Specifications are not part of the text of the final document, although they contain instructions that the Procuring Entity should strictly follow.

- d. The cover should be modified as required to identify the Bidding Documents as to the Procurement Project, Project Identification Number, and Procuring Entity, in addition to the date of issue.
- e. Modifications for specific Procurement Project details should be provided in the Special Conditions of Contract as amendments to the Conditions of Contract. For easy completion, whenever reference has to be made to specific clauses in the Bid Data Sheet or Special Conditions of Contract, these terms shall be printed in bold typeface on Sections I (Instructions to Bidders) and III (General Conditions of Contract), respectively.
- f. For guidelines on the use of Bidding Forms and the procurement of Foreign-Assisted Projects, these will be covered by a separate issuance of the Government Procurement Policy Board.

# Table of Contents

<b>Glossary of Acronyms, Terms, and Abbreviations .....</b>	<b>4</b>
<b>Section I. Invitation to Bid.....</b>	<b>7</b>
<b>Section II. Instructions to Bidders.....</b>	<b>11</b>
1. Scope of Bid .....	12
2. Funding Information.....	12
3. Bidding Requirements .....	12
4. Corrupt, Fraudulent, Collusive, and Coercive Practices.....	12
5. Eligible Bidders.....	12
6. Origin of Goods .....	13
7. Subcontracts .....	13
8. Pre-Bid Conference .....	13
9. Clarification and Amendment of Bidding Documents .....	14
10. Documents comprising the Bid: Eligibility and Technical Components .....	14
11. Documents comprising the Bid: Financial Component .....	14
12. Bid Prices .....	14
13. Bid and Payment Currencies .....	15
14. Bid Security .....	15
15. Sealing and Marking of Bids .....	16
16. Deadline for Submission of Bids .....	16
17. Opening and Preliminary Examination of Bids .....	16
18. Domestic Preference .....	16
19. Detailed Evaluation and Comparison of Bids .....	16
20. Post-Qualification .....	17
21. Signing of the Contract .....	17
<b>Section III. Bid Data Sheet .....</b>	<b>18</b>
<b>Section IV. General Conditions of Contract .....</b>	<b>21</b>
1. Scope of Contract .....	22
2. Advance Payment and Terms of Payment .....	22
3. Performance Security .....	22
4. Inspection and Tests .....	22
5. Warranty .....	23
6. Liability of the Supplier .....	23
<b>Section V. Special Conditions of Contract .....</b>	<b>24</b>
<b>Section VI. Schedule of Requirements .....</b>	<b>30</b>
<b>Section VII. Technical Specifications .....</b>	<b>37</b>
<b>Section VIII. Checklist of Technical and Financial Documents .....</b>	<b>48</b>

# *Glossary of Acronyms, Terms, and Abbreviations*

**ABC** – Approved Budget for the Contract.

**BAC** – Bids and Awards Committee.

**Bid** – A signed offer or proposal to undertake a contract submitted by a bidder in response to and in consonance with the requirements of the bidding documents. Also referred to as *Proposal* and *Tender*. (2016 revised IRR, Section 5[c])

**Bidder** – Refers to a contractor, manufacturer, supplier, distributor and/or consultant who submits a bid in response to the requirements of the Bidding Documents. (2016 revised IRR, Section 5[d])

**Bidding Documents** – The documents issued by the Procuring Entity as the bases for bids, furnishing all information necessary for a prospective bidder to prepare a bid for the Goods, Infrastructure Projects, and/or Consulting Services required by the Procuring Entity. (2016 revised IRR, Section 5[e])

**BIR** – Bureau of Internal Revenue.

**BSP** – Bangko Sentral ng Pilipinas.

**Consulting Services** – Refer to services for Infrastructure Projects and other types of projects or activities of the GOP requiring adequate external technical and professional expertise that are beyond the capability and/or capacity of the GOP to undertake such as, but not limited to: (i) advisory and review services; (ii) pre-investment or feasibility studies; (iii) design; (iv) construction supervision; (v) management and related services; and (vi) other technical services or special studies. (2016 revised IRR, Section 5[i])

**CDA** - Cooperative Development Authority.

**Contract** – Refers to the agreement entered into between the Procuring Entity and the Supplier or Manufacturer or Distributor or Service Provider for procurement of Goods and Services; Contractor for Procurement of Infrastructure Projects; or Consultant or Consulting Firm for Procurement of Consulting Services; as the case may be, as recorded in the Contract Form signed by the parties, including all attachments and appendices thereto and all documents incorporated by reference therein.

**CIF** – Cost Insurance and Freight.

**CIP** – Carriage and Insurance Paid.

**CPI** – Consumer Price Index.

**DDP** – Refers to the quoted price of the Goods, which means “delivered duty paid.”

**DTI** – Department of Trade and Industry.

**EXW** – Ex works.

**FCA** – “Free Carrier” shipping point.

**FOB** – “Free on Board” shipping point.

**Foreign-funded Procurement or Foreign-Assisted Project**– Refers to procurement whose funding source is from a foreign government, foreign or international financing institution as specified in the Treaty or International or Executive Agreement. (2016 revised IRR, Section 5[b]).

**Framework Agreement** – Refers to a written agreement between a procuring entity and a supplier or service provider that identifies the terms and conditions, under which specific purchases, otherwise known as “Call-Offs,” are made for the duration of the agreement. It is in the nature of an option contract between the procuring entity and the bidder(s) granting the procuring entity the option to either place an order for any of the goods or services identified in the Framework Agreement List or not buy at all, within a minimum period of one (1) year to a maximum period of three (3) years. (GPPB Resolution No. 27-2019)

**GFI** – Government Financial Institution.

**GOCC** – Government-owned and/or –controlled corporation.

**Goods** – Refer to all items, supplies, materials and general support services, except Consulting Services and Infrastructure Projects, which may be needed in the transaction of public businesses or in the pursuit of any government undertaking, project or activity, whether in the nature of equipment, furniture, stationery, materials for construction, or personal property of any kind, including non-personal or contractual services such as the repair and maintenance of equipment and furniture, as well as trucking, hauling, janitorial, security, and related or analogous services, as well as procurement of materials and supplies provided by the Procuring Entity for such services. The term “related” or “analogous services” shall include, but is not limited to, lease or purchase of office space, media advertisements, health maintenance services, and other services essential to the operation of the Procuring Entity. (2016 revised IRR, Section 5[r])

**GOP** – Government of the Philippines.

**GPPB** – Government Procurement Policy Board.

**INCOTERMS** – International Commercial Terms.

**Infrastructure Projects** – Include the construction, improvement, rehabilitation, demolition, repair, restoration or maintenance of roads and bridges, railways, airports, seaports, communication facilities, civil works components of information technology projects, irrigation, flood control and drainage, water supply, sanitation, sewerage and solid waste management systems, shore protection, energy/power and electrification facilities, national

buildings, school buildings, hospital buildings, and other related construction projects of the government. Also referred to as *civil works or works*. (2016 revised IRR, Section 5[u])

**LGUs** – Local Government Units.

**NFCC** – Net Financial Contracting Capacity.

**NGA** – National Government Agency.

**PhilGEPS** - Philippine Government Electronic Procurement System.

**Procurement Project** – refers to a specific or identified procurement covering goods, infrastructure project or consulting services. A Procurement Project shall be described, detailed, and scheduled in the Project Procurement Management Plan prepared by the agency which shall be consolidated in the procuring entity's Annual Procurement Plan. (GPPB Circular No. 06-2019 dated 17 July 2019)

**PSA** – Philippine Statistics Authority.

**SEC** – Securities and Exchange Commission.

**SLCC** – Single Largest Completed Contract.

**Supplier** – refers to a citizen, or any corporate body or commercial company duly organized and registered under the laws where it is established, habitually established in business and engaged in the manufacture or sale of the merchandise or performance of the general services covered by his bid. (Item 3.8 of GPPB Resolution No. 13-2019, dated 23 May 2019). Supplier as used in these Bidding Documents may likewise refer to a distributor, manufacturer, contractor, or consultant.

**UN** – United Nations.

## ***Section I. Invitation to Bid***

### **Notes on the Invitation to Bid**

The Invitation to Bid (IB) provides information that enables potential Bidders to decide whether to participate in the procurement at hand. The IB shall be posted in accordance with Section 21.2 of the 2016 revised IRR of RA No. 9184.

Apart from the essential items listed in the Bidding Documents, the IB should also indicate the following:

- a. The date of availability of the Bidding Documents, which shall be from the time the IB is first advertised/posted until the deadline for the submission and receipt of bids;
- b. The place where the Bidding Documents may be acquired or the website where it may be downloaded;
- c. The deadline for the submission and receipt of bids; and
- d. Any important bid evaluation criteria (*e.g.*, the application of a margin of preference in bid evaluation).

The IB should be incorporated in the Bidding Documents. The information contained in the IB must conform to the Bidding Documents and in particular to the relevant information in the Bid Data Sheet.





REPUBLIC OF THE PHILIPPINES  
**DIGOS WATER DISTRICT**  
RIZAL AVENUE, DIGOS CITY

**INVITATION TO BID FOR THE SUPPLY, DELIVERY,  
INSTALLATION, TESTING AND COMMISSIONING OF ELECTRO-  
MECHANICAL EQUIPMENT FOR THE NEW PUMPING STATION AT  
BRGY. TIGUMAN, DIGOS CITY**

1. The Digos Water District, through the Corporate Budget for the year 2024, intends to apply the sum of **Four Million, Four Hundred Thousand Pesos (Php 4,400,000.00)** being the ABC to payments under the contract for:

	PARTICULARS	AMOUNT OF ABC	AMOUNT OF BID DOCS
Purchase Request No. 2024-08-0003	Electro-Mechanical Equipment (Brgy. Tiguman)	Php 4,400,000.00	4,500.00
	Total Amount of ABC, and Bid Docs	Php 4,400,000.00	4,500.00

Bids received in excess of the ABC shall be automatically rejected at bid opening.

2. The **Digos Water District** now invites bids for the above Procurement Project. Delivery, Installation, Testing and Commissioning of the Goods is required by **60 Calendar days upon receipt of Purchase Order**. Bidders should have completed, within two (2) years from the date of submission and receipt of bids, a contract similar to the Project. The description of an eligible bidder is contained in the Bidding Documents, particularly, in Section II (Instructions to Bidders).
3. Bidding will be conducted through open competitive bidding procedures using a non-discretionary “*pass/fail*” criterion as specified in the 2016 revised Implementing Rules and Regulations (IRR) of Republic Act (RA) No. 9184.

Bidding is restricted to Filipino citizens/sole proprietorships, partnerships, or organizations with at least sixty percent (60%) interest or outstanding capital stock belonging to citizens of the Philippines, and to citizens or organizations of a country the laws or regulations of which grant similar rights or privileges to Filipino citizens, pursuant to RA No. 5183.

4. Prospective Bidders may obtain further information from Digos Water District and inspect the Bidding Documents at the address given below during **Mondays to Fridays, 8:00 a.m to 5:00 p.m.**
5. A complete set of Bidding Documents may be acquired by interested Bidders on **August 12, 2024** from the given address and website/s below *and upon payment of the*

*applicable fee for the Bidding Documents, pursuant to the latest Guidelines issued by the GPPB, in the amount of **Four Thousand Five Hundred Pesos (Php 4,500.00)**. The Procuring Entity shall allow the bidder to present its proof of payment for the fees presented in person, or through electronic means.*

6. The Digos Water District will hold a Pre-Bid Conference<sup>1</sup> on **August 22, 2024 at 9:00 in the morning** at Digos Water District Board Room and/or through video conferencing or webcasting via **Google Meet** (*the link will be provided at least 15 minutes before the Pre-Bid Conference*), which shall be open to prospective bidders.
7. Bids must be duly received by the BAC Secretariat through (i) manual/personal delivery/ submission at the office address indicated below, or (ii) through courier on or before **September 4, 2024 at 8:45 in the morning**. Late bids shall not be accepted.
8. All Bids must be accompanied by a bid security in any of the acceptable forms and in the amount stated in **ITB** Clause 14.
9. Bid opening shall be on **September 4, 2024 at 9:00 in the morning** at the given address below and/or through video conferencing or webcasting via **Google Meet** (*the link will be provided at least 15 minutes before the Bid Opening*). Bids will be opened in the presence of the bidders' representatives who choose to attend the activity.
10. The Digos Water District reserves the right to reject any and all bids, declare a failure of bidding, or not award the contract at any time prior to contract award in accordance with Sections 35.6 and 41 of the 2016 revised IRR of RA No. 9184, without thereby incurring any liability to the affected bidder or bidders.
11. For further information, please refer to:

**JOVITO V. TOLARES**  
*Head - BAC Secretariat*  
*Digos Water District*  
*Rizal Avenue, Digos City, Davao del Sur*  
*Telefax no. (082)553-8742*  
*dwdprocurement@gmail.com*

12. You may visit the following websites:

**For downloading of Bidding Documents:** <https://notices.philgeps.gov.ph>  
<https://digoswaterdistrict.gov.ph/>

**August 12, 2024**

---

<sup>1</sup> May be deleted in case the ABC is less than One Million Pesos (PhP1,000,000) where the Procuring Entity may not hold a Pre-Bid Conference.

APHRODITE M. ADRALES  
BAC Chairperson

## ***Section II. Instructions to Bidders***

### **Notes on the Instructions to Bidders**

This Section on the Instruction to Bidders (ITB) provides the information necessary for bidders to prepare responsive bids, in accordance with the requirements of the Procuring Entity. It also provides information on bid submission, eligibility check, opening and evaluation of bids, post-qualification, and on the award of contract.

## 1. Scope of Bid

The Procuring Entity, **Digos Water District**, wishes to receive Bids for the **Supply, Delivery, Installation, Testing and Commissioning of Electro-Mechanical Equipment for the New Pumping Station at Brgy. Tiguman, Digos City** with identification number **PR#2024-07-0017**.

The Procurement Project (referred to herein as “Project”) is composed of **one (1) lot**, the details of which are described in Section VII (Technical Specifications).

## 2. Funding Information

2.1. The GOP through the source of funding as indicated below for *CY 2024* in the amount of **Four Million, Four Hundred Pesos (Php 4,400,000.00)**.

2.2. The source of funding is GOCC and GFIs, the Corporate Operating Budget.

## 3. Bidding Requirements

The Bidding for the Project shall be governed by all the provisions of RA No. 9184 and its 2016 revised IRR, including its Generic Procurement Manuals and associated policies, rules and regulations as the primary source thereof, while the herein clauses shall serve as the secondary source thereof.

Any amendments made to the IRR and other GPPB issuances shall be applicable only to the ongoing posting, advertisement, or **IB** by the BAC through the issuance of a supplemental or bid bulletin.

The Bidder, by the act of submitting its Bid, shall be deemed to have verified and accepted the general requirements of this Project, including other factors that may affect the cost, duration and execution or implementation of the contract, project, or work and examine all instructions, forms, terms, and project requirements in the Bidding Documents.

## 4. Corrupt, Fraudulent, Collusive, and Coercive Practices

The Procuring Entity, as well as the Bidders and Suppliers, shall observe the highest standard of ethics during the procurement and execution of the contract. They or through an agent shall not engage in corrupt, fraudulent, collusive, coercive, and obstructive practices defined under Annex “I” of the 2016 revised IRR of RA No. 9184 or other integrity violations in competing for the Project.

## 5. Eligible Bidders

- 5.1. Only Bids or Bidders found to be legally, technically, and financially capable will be evaluated.
- 5.2. Foreign ownership limited to those allowed under the rules may participate in this Project.
- 5.3. Pursuant to Section 23.4.1.3 of the 2016 revised IRR of RA No.9184, the Bidder shall have an SLCC that is at least one (1) contract similar to the Project the value of which, adjusted to current prices using the PSA's CPI, must be at least equivalent to:
  - a. For the procurement of Non-expendable Supplies and Services: The Bidder must have completed a single contract that is similar to this Project, equivalent to at least fifty percent (50%) of the ABC.
  - b. For the procurement of Expendable Supplies: The Bidder must have completed a single contract that is similar to this Project, equivalent to at least twenty-five percent (25%) of the ABC.
  - c. For procurement where the Procuring Entity has determined, after the conduct of market research, that imposition of either (a) or (b) will likely result to failure of bidding or monopoly that will defeat the purpose of public bidding: the Bidder should comply with the following requirements: *[Select either failure or monopoly of bidding based on market research conducted]*
    - i. Completed at least two (2) similar contracts, the aggregate amount of which should be equivalent to at least *fifty percent (50%) in the case of non-expendable supplies and services or twenty-five percent (25%) in the case of expendable supplies* of the ABC for this Project; and
    - ii. The largest of these similar contracts must be equivalent to at least half of the percentage of the ABC as required above.
- 5.4. The Bidders shall comply with the eligibility criteria under Section 23.4.1 of the 2016 IRR of RA No. 9184.

## 6. Origin of Goods

There is no restriction on the origin of goods other than those prohibited by a decision of the UN Security Council taken under Chapter VII of the Charter of the UN, subject to Domestic Preference requirements under **ITB** Clause 18.

## 7. Subcontracts

The Procuring Entity has prescribed that Subcontracting is not allowed.

## 8. Pre-Bid Conference

The Procuring Entity will hold a pre-bid conference for this Project on the specified date and time and either at its physical address and/or through videoconferencing/webcasting as indicated in paragraph 6 of the **IB**.

## **9. Clarification and Amendment of Bidding Documents**

Prospective bidders may request for clarification on and/or interpretation of any part of the Bidding Documents. Such requests must be in writing and received by the Procuring Entity, either at its given address or through electronic mail indicated in the **IB**, at least ten (10) calendar days before the deadline set for the submission and receipt of Bids.

## **10. Documents comprising the Bid: Eligibility and Technical Components**

- 10.1. The first envelope shall contain the eligibility and technical documents of the Bid as specified in **Section VIII (Checklist of Technical and Financial Documents)**.
- 10.2. The Bidder's SLCC as indicated in **ITB** Clause 5.3 should have been completed within *two (2) years* prior to the deadline for the submission and receipt of bids.
- 10.3. If the eligibility requirements or statements, the bids, and all other documents for submission to the BAC are in foreign language other than English, it must be accompanied by a translation in English, which shall be authenticated by the appropriate Philippine foreign service establishment, post, or the equivalent office having jurisdiction over the foreign bidder's affairs in the Philippines. Similar to the required authentication above, for Contracting Parties to the Apostille Convention, only the translated documents shall be authenticated through an apostille pursuant to GPPB Resolution No. 13-2019 dated 23 May 2019. The English translation shall govern, for purposes of interpretation of the bid.

## **11. Documents comprising the Bid: Financial Component**

- 11.1. The second bid envelope shall contain the financial documents for the Bid as specified in **Section VIII (Checklist of Technical and Financial Documents)**.
- 11.2. If the Bidder claims preference as a Domestic Bidder or Domestic Entity, a certification issued by DTI shall be provided by the Bidder in accordance with Section 43.1.3 of the 2016 revised IRR of RA No. 9184.
- 11.3. Any bid exceeding the ABC indicated in paragraph 1 of the **IB** shall not be accepted.
- 11.4. For Foreign-funded Procurement, a ceiling may be applied to bid prices provided the conditions are met under Section 31.2 of the 2016 revised IRR of RA No. 9184.

## **12. Bid Prices**

12.1. Prices indicated on the Price Schedule shall be entered separately in the following manner:

a. For Goods offered from within the Procuring Entity's country:

- i. The price of the Goods quoted EXW (ex-works, ex-factory, ex-warehouse, ex-showroom, or off-the-shelf, as applicable);
- ii. The cost of all customs duties and sales and other taxes already paid or payable;
- iii. The cost of transportation, insurance, and other costs incidental to delivery of the Goods to their final destination; and
- iv. The price of other (incidental) services, if any, listed in the **BDS**.

b. For Goods offered from abroad:

- i. Unless otherwise stated in the **BDS**, the price of the Goods shall be quoted delivered duty paid (DDP) with the place of destination in the Philippines as specified in the **BDS**. In quoting the price, the Bidder shall be free to use transportation through carriers registered in any eligible country. Similarly, the Bidder may obtain insurance services from any eligible source country.
- ii. The price of other (incidental) services, if any, as listed in the **BDS**.

### **13. Bid and Payment Currencies**

13.1. For Goods that the Bidder will supply from outside the Philippines, the bid prices may be quoted in the local currency or tradeable currency accepted by the BSP at the discretion of the Bidder. However, for purposes of bid evaluation, Bids denominated in foreign currencies, shall be converted to Philippine currency based on the exchange rate as published in the BSP reference rate bulletin on the day of the bid opening.

13.2. Payment of the contract price shall be made in Philippine Pesos.

### **14. Bid Security**

14.1. The Bidder shall submit a Bid Securing Declaration<sup>2</sup> or any form of Bid Security in the amount indicated in the **BDS**, which shall be not less than the percentage of the ABC in accordance with the schedule in the **BDS**.

14.2. The Bid and bid security shall be valid until **one hundred twenty (120) calendar days from the date of the Opening of Bids**. Any Bid not accompanied by an acceptable bid security shall be rejected by the Procuring Entity as non-responsive.

---

<sup>2</sup> In the case of Framework Agreement, the undertaking shall refer to entering into contract with the Procuring Entity and furnishing of the performance security or the performance securing declaration within ten (10) calendar days from receipt of Notice to Execute Framework Agreement.



## **15. Sealing and Marking of Bids**

Each Bidder shall submit one copy of the first and second components of its Bid.

The Procuring Entity may request additional hard copies and/or electronic copies of the Bid. However, failure of the Bidders to comply with the said request shall not be a ground for disqualification.

If the Procuring Entity allows the submission of bids through online submission or any other electronic means, the Bidder shall submit an electronic copy of its Bid, which must be digitally signed. An electronic copy that cannot be opened or is corrupted shall be considered non-responsive and, thus, automatically disqualified.

## **16. Deadline for Submission of Bids**

16.1. The Bidders shall submit on the specified date and time and either through manual/physical delivery at its physical address or via courier as indicated in paragraph 7 of the **IB**.

## **17. Opening and Preliminary Examination of Bids**

17.1. The BAC shall open the Bids in public at the time, on the date, and at the place specified in paragraph 9 of the **IB**. The Bidders' representatives who are present shall sign a register evidencing their attendance. In case videoconferencing, webcasting or other similar technologies will be used, attendance of participants shall likewise be recorded by the BAC Secretariat.

In case the Bids cannot be opened as scheduled due to justifiable reasons, the rescheduling requirements under Section 29 of the 2016 revised IRR of RA No. 9184 shall prevail.

17.2. The preliminary examination of bids shall be governed by Section 30 of the 2016 revised IRR of RA No. 9184.

## **18. Domestic Preference**

18.1. The Procuring Entity will grant a margin of preference for the purpose of comparison of Bids in accordance with Section 43.1.2 of the 2016 revised IRR of RA No. 9184.

## **19. Detailed Evaluation and Comparison of Bids**

19.1. The Procuring Entity's BAC shall immediately conduct a detailed evaluation of all Bids rated "*passed*," using non-discretionary pass/fail criteria. The BAC shall consider the conditions in the evaluation of Bids under Section 32.2 of the 2016 revised IRR of RA No. 9184.

19.2. If the Project allows partial bids, bidders may submit a proposal on any of the lots or items, and evaluation will be undertaken on a per lot or item basis, as the

case maybe. In this case, the Bid Security as required by **ITB** Clause 14 shall be submitted for each lot or item separately.

19.3. The descriptions of the lots or items shall be indicated in **Section VII (Technical Specifications)**, although the ABCs of these lots or items are indicated in the **BDS** for purposes of the NFCC computation pursuant to Section 23.4.2.6 of the 2016 revised IRR of RA No. 9184. The NFCC must be sufficient for the total of the ABCs for all the lots or items participated in by the prospective Bidder.

19.4. The Project shall be awarded as follows:

Option 2 – One Project having several items grouped into several lots, which shall be awarded as separate contracts per lot.

19.5. Except for bidders submitting a committed Line of Credit from a Universal or Commercial Bank in lieu of its NFCC computation, all Bids must include the NFCC computation pursuant to Section 23.4.1.4 of the 2016 revised IRR of RA No. 9184, which must be sufficient for the total of the ABCs for all the lots or items participated in by the prospective Bidder. For bidders submitting the committed Line of Credit, it must be at least equal to ten percent (10%) of the ABCs for all the lots or items participated in by the prospective Bidder.

## **20. Post-Qualification**

20.1. Within a non-extendible period of five (5) calendar days from receipt by the Bidder of the notice from the BAC that it submitted the Lowest Calculated Bid, the Bidder shall submit its latest income and business tax returns filed and paid through the BIR Electronic Filing and Payment System (eFPS) and other appropriate licenses and permits required by law and stated in the **BDS**.

## **21. Signing of the Contract**

21.1. The documents required in Section 37.2 of the 2016 revised IRR of RA No. 9184 shall form part of the Contract. Additional Contract documents are indicated in the **BDS**.

## ***Section III. Bid Data Sheet***

### **Notes on the Bid Data Sheet**

The Bid Data Sheet (BDS) consists of provisions that supplement, amend, or specify in detail, information, or requirements included in the ITB found in Section II, which are specific to each procurement.

This Section is intended to assist the Procuring Entity in providing the specific information in relation to corresponding clauses in the ITB and has to be prepared for each specific procurement.

The Procuring Entity should specify in the BDS information and requirements specific to the circumstances of the Procuring Entity, the processing of the procurement, and the bid evaluation criteria that will apply to the Bids. In preparing the BDS, the following aspects should be checked:

- a. Information that specifies and complements provisions of the ITB must be incorporated.
- b. Amendments and/or supplements, if any, to provisions of the ITB as necessitated by the circumstances of the specific procurement, must also be incorporated.

# Bid Data Sheet

ITB Clause																
5.3	<p>The Bidder must have completed a single contract that is similar to this Project, equivalent to at least fifty percent (50%) of the ABC.</p> <p>The Bidder must have a single contract completed within two (2) years prior to the deadline for the submission and receipt of bids.</p> <p>For this purpose, contracts similar to the Project which have the same major categories of work, and which shall refer to supply of pipes, fittings, and/or construction materials and supplies.</p>															
7.1	Subcontracting is not allowed.															
12	The price of the Goods shall be quoted DDP <b><i>Brgy Tiguman, Digos City</i></b> or the applicable International Commercial Terms (INCOTERMS) for this Project.															
14.1	<p>The bid security shall be in the form of a Bid Securing Declaration, or any of the following forms and amounts:</p> <p style="margin-left: 40px;">a. The amount of not less than <b>Php 88,000.00</b> <i>equivalent to two percent (2%) of ABC</i>, if bid security is in cash, cashier's/manager's check, bank draft/guarantee or irrevocable letter of credit; or</p> <p style="margin-left: 40px;">b. The amount of not less than <b>Php 220,000.00</b> <i>equivalent to five percent (5%) of ABC</i> if bid security is in Surety Bond.</p>															
15	Each Bidder shall submit <b>1 original and 1 copy</b> of the first and second components of its bid.															
19.3	<p>The project will be awarded by lot as follows:</p> <table border="1" style="width: 100%; border-collapse: collapse; margin-top: 10px;"> <thead> <tr> <th style="width: 15%;"></th> <th style="width: 15%;"></th> <th style="width: 40%; text-align: center;">PARTICULARS</th> <th style="width: 15%; text-align: center;">AMOUNT OF ABC</th> <th style="width: 15%; text-align: center;">AMOUNT OF BID DOCS</th> </tr> </thead> <tbody> <tr> <td style="text-align: center;">Purchase Request No. 2024-04-0017</td> <td></td> <td>Supply, Delivery, Installation, Testing and Commissioning of Electro-Mechanical Equipment for the New Pumping Station at Brgy. Tiguman, Digos City</td> <td style="text-align: right;">Php 4,400,000.00</td> <td style="text-align: right;">4,500.00</td> </tr> <tr> <td></td> <td></td> <td style="text-align: center;">Total Amount of ABC and Bid Docs</td> <td style="text-align: right;">Php 4,400,000.00</td> <td style="text-align: right;">4,500.00</td> </tr> </tbody> </table>			PARTICULARS	AMOUNT OF ABC	AMOUNT OF BID DOCS	Purchase Request No. 2024-04-0017		Supply, Delivery, Installation, Testing and Commissioning of Electro-Mechanical Equipment for the New Pumping Station at Brgy. Tiguman, Digos City	Php 4,400,000.00	4,500.00			Total Amount of ABC and Bid Docs	Php 4,400,000.00	4,500.00
		PARTICULARS	AMOUNT OF ABC	AMOUNT OF BID DOCS												
Purchase Request No. 2024-04-0017		Supply, Delivery, Installation, Testing and Commissioning of Electro-Mechanical Equipment for the New Pumping Station at Brgy. Tiguman, Digos City	Php 4,400,000.00	4,500.00												
		Total Amount of ABC and Bid Docs	Php 4,400,000.00	4,500.00												

20.2	<p>The following post-qualification documents must be submitted within a non-extendible period of five (5) calendar days from the receipt by the bidder of the notice from the BAC that it submitted the Lowest Calculated Bid:</p> <ol style="list-style-type: none"> <li>1. <b>Latest Income and Business Tax Returns</b> filed and paid through the BIR Electronic Filing and Payment System (eFPS);</li> <li>2. <b>Affidavit of site inspection.</b></li> </ol>
21.1	<p><i>Additional contract document/s relevant to the Project that may be required by existing laws and/or the Procuring Entity:</i></p> <p>The following document shall form part of the <b>Contract Documents</b>, and shall be submitted by the winning bidder within <b>ten (10) calendar days from the receipt of the Notice of Award:</b></p> <ol style="list-style-type: none"> <li>(1) <b>Installation, Testing and Commissioning Schedule</b> (bar chart for the installation, testing and commissioning activities).</li> </ol>

## ***Section IV. General Conditions of Contract***

### **Notes on the General Conditions of Contract**

The General Conditions of Contract (GCC) in this Section, read in conjunction with the Special Conditions of Contract in Section V and other documents listed therein, should be a complete document expressing all the rights and obligations of the parties.

Matters governing performance of the Supplier, payments under the contract, or matters affecting the risks, rights, and obligations of the parties under the contract are included in the GCC and Special Conditions of Contract.

Any complementary information, which may be needed, shall be introduced only through the Special Conditions of Contract.

## 1. Scope of Contract

This Contract shall include all such items, although not specifically mentioned, that can be reasonably inferred as being required for its completion as if such items were expressly mentioned herein. All the provisions of RA No. 9184 and its 2016 revised IRR, including the Generic Procurement Manual, and associated issuances, constitute the primary source for the terms and conditions of the Contract, and thus, applicable in contract implementation. Herein clauses shall serve as the secondary source for the terms and conditions of the Contract.

This is without prejudice to Sections 74.1 and 74.2 of the 2016 revised IRR of RA No. 9184 allowing the GPPB to amend the IRR, which shall be applied to all procurement activities, the advertisement, posting, or invitation of which were issued after the effectivity of the said amendment.

Additional requirements for the completion of this Contract shall be provided in the **Special Conditions of Contract (SCC)**.

## 2. Advance Payment and Terms of Payment

2.1. Advance payment of the contract amount is provided under Annex “D” of the revised 2016 IRR of RA No. 9184.

2.2. The Procuring Entity is allowed to determine the terms of payment on the partial or staggered delivery of the Goods procured, provided such partial payment shall correspond to the value of the goods delivered and accepted in accordance with prevailing accounting and auditing rules and regulations. The terms of payment are indicated in the **SCC**.

## 3. Performance Security

Within ten (10) calendar days from receipt of the Notice of Award by the Bidder from the Procuring Entity but in no case later than the signing of the Contract by both parties, the successful Bidder shall furnish the performance security in any of the forms prescribed in Section 39 of the 2016 revised IRR of RA No. 9184.

## 4. Inspection and Tests

The Procuring Entity or its representative shall have the right to inspect and/or to test the Goods to confirm their conformity to the Project specifications at no extra cost to the Procuring Entity in accordance with the Generic Procurement Manual. In addition to tests in the **SCC, Section VII (Technical Specifications)** shall specify what inspections and/or tests the Procuring Entity requires, and where they are to be conducted. The Procuring Entity shall notify the Supplier in writing, in a timely manner, of the identity of any representatives retained for these purposes.

All reasonable facilities and assistance for the inspection and testing of Goods, including access to drawings and production data, shall be provided by the Supplier to the authorized inspectors at no charge to the Procuring Entity.

## **5. Warranty**

- 5.1 In order to assure that manufacturing defects shall be corrected by the Supplier, a warranty shall be required from the Supplier as provided under Section 62.1 of the 2016 revised IRR of RA No. 9184.
- 5.2 The Procuring Entity shall promptly notify the Supplier in writing of any claims arising under this warranty. Upon receipt of such notice, the Supplier shall, repair or replace the defective Goods or parts thereof without cost to the Procuring Entity, pursuant to the Generic Procurement Manual.

## **6. Liability of the Supplier**

The Supplier's liability under this Contract shall be as provided by the laws of the Republic of the Philippines.

If the Supplier is a joint venture, all partners to the joint venture shall be jointly and severally liable to the Procuring Entity.



## ***Section V. Special Conditions of Contract***

### **Notes on the Special Conditions of Contract**

Similar to the BDS, the clauses in this Section are intended to assist the Procuring Entity in providing contract-specific information in relation to corresponding clauses in the GCC found in Section IV.

The Special Conditions of Contract (SCC) complement the GCC, specifying contractual requirements linked to the special circumstances of the Procuring Entity, the Procuring Entity's country, the sector, and the Goods purchased. In preparing this Section, the following aspects should be checked:

- a. Information that complements provisions of the GCC must be incorporated.
- b. Amendments and/or supplements to provisions of the GCC as necessitated by the circumstances of the specific purchase, must also be incorporated.

However, no special condition which defeats or negates the general intent and purpose of the provisions of the GCC should be incorporated herein.

## Special Conditions of Contract

GCC Clause	
1	<p><b>Delivery and Documents –</b></p> <p>For purposes of the Contract, “EXW,” “FOB,” “FCA,” “CIF,” “CIP,” “DDP” and other trade terms used to describe the obligations of the parties shall have the meanings assigned to them by the current edition of INCOTERMS published by the International Chamber of Commerce, Paris. The Delivery terms of this Contract shall be as follows:</p> <p><i>[For Goods supplied from abroad:]</i> “The delivery terms applicable to the Contract are DDP delivered to <i>Brgy. Tiguman, Digos City</i>. In accordance with INCOTERMS.”</p> <p><i>[For Goods supplied from within the Philippines:]</i> “The delivery terms applicable to this Contract are delivered to <i>Brgy. Tiguman, Digos City</i>. Risk and title will pass from the Supplier to the Procuring Entity upon receipt and final acceptance of the Goods at their final destination.”</p> <p>Delivery of the Goods shall be made by the Supplier in accordance with the terms specified in Section VI (Schedule of Requirements).</p> <p>For purposes of this Clause the Procuring Entity’s Representatives at the Project Site are <b>Engr. Michael Jr. Calapan and Engr. John Rhodel Ybañez</b>.</p> <p><b>Incidental Services –</b></p> <p>The Supplier is required to provide all of the following services, including additional services, if any, specified in Section VI. Schedule of Requirements:</p> <ol style="list-style-type: none"> <li>a. performance or supervision of on-site assembly and/or start-up of the supplied Goods;</li> <li>b. furnishing of tools required for assembly and/or maintenance of the supplied Goods;</li> <li>c. furnishing of a detailed operations and maintenance manual for each appropriate unit of the supplied Goods;</li> <li>d. performance or supervision or maintenance and/or repair of the supplied Goods, for a period of time agreed by the parties, provided that this service shall not relieve the Supplier of any warranty obligations under this Contract; and</li> </ol>

- e. training of the Procuring Entity’s personnel, at the Supplier’s plant and/or on-site, in assembly, start-up, operation, maintenance, and/or repair of the supplied Goods.

The Contract price for the Goods shall include the prices charged by the Supplier for incidental services and shall not exceed the prevailing rates charged to other parties by the Supplier for similar services.

**Spare Parts –**

The Supplier is required to provide all of the following materials, notifications, and information pertaining to spare parts manufactured or distributed by the Supplier:

- a. such spare parts as the Procuring Entity may elect to purchase from the Supplier, provided that this election shall not relieve the Supplier of any warranty obligations under this Contract; and
- b. in the event of termination of production of the spare parts:
  - i. advance notification to the Procuring Entity of the pending termination, in sufficient time to permit the Procuring Entity to procure needed requirements; and
  - ii. following such termination, furnishing at no cost to the Procuring Entity, the blueprints, drawings, and specifications of the spare parts, if requested.

The spare parts and other components required are listed in **Section VI (Schedule of Requirements)** and the costs thereof are included in the contract price.

The Supplier shall carry sufficient inventories to assure ex-stock supply of consumable spare parts or components for the Goods for a period of [*indicate here the time period specified. If not used indicate a time period of three times the warranty period*].

Spare parts or components shall be supplied as promptly as possible, but in any case, within [*insert appropriate time period*] months of placing the order.

	<p><b>Packaging –</b></p> <p>The Supplier shall provide such packaging of the Goods as is required to prevent their damage or deterioration during transit to their final destination, as indicated in this Contract. The packaging shall be sufficient to withstand, without limitation, rough handling during transit and exposure to extreme temperatures, salt and precipitation during transit, and open storage. Packaging case size and weights shall take into consideration, where appropriate, the remoteness of the Goods’ final destination and the absence of heavy handling facilities at all points in transit.</p> <p>The packaging, marking, and documentation within and outside the packages shall comply strictly with such special requirements as shall be expressly provided for in the Contract, including additional requirements, if any, specified below, and in any subsequent instructions ordered by the Procuring Entity.</p> <p>The outer packaging must be clearly marked on at least four (4) sides as follows:</p> <p>Name of the Procuring Entity  Name of the Supplier  Contract Description  Final Destination  Gross weight  Any special lifting instructions  Any special handling instructions  Any relevant HAZCHEM classifications</p>
	<p>A packaging list identifying the contents and quantities of the package is to be placed on an accessible point of the outer packaging if practical. If not practical the packaging list is to be placed inside the outer packaging but outside the secondary packaging.</p> <p><b>Transportation –</b></p> <p>Where the Supplier is required under Contract to deliver the Goods CIF, CIP, or DDP, transport of the Goods to the port of destination or such other named place of destination in the Philippines, as shall be specified in this Contract, shall be arranged and paid for by the Supplier, and the cost thereof shall be included in the Contract Price.</p> <p>Where the Supplier is required under this Contract to transport the Goods to a specified place of destination within the Philippines, defined as the Project Site, transport to such place of destination in the Philippines, including insurance and storage, as shall be specified in this Contract, shall be arranged by the Supplier, and related costs shall be included in the contract price.</p>

	<p>Where the Supplier is required under Contract to deliver the Goods CIF, CIP or DDP, Goods are to be transported on carriers of Philippine registry. In the event that no carrier of Philippine registry is available, Goods may be shipped by a carrier which is not of Philippine registry provided that the Supplier obtains and presents to the Procuring Entity certification to this effect from the nearest Philippine consulate to the port of dispatch. In the event that carriers of Philippine registry are available but their schedule delays the Supplier in its performance of this Contract the period from when the Goods were first ready for shipment and the actual date of shipment the period of delay will be considered force majeure.</p> <p>The Procuring Entity accepts no liability for the damage of Goods during transit other than those prescribed by INCOTERMS for DDP deliveries. In the case of Goods supplied from within the Philippines or supplied by domestic Suppliers risk and title will not be deemed to have passed to the Procuring Entity until their receipt and final acceptance at the final destination.</p> <p><b>Intellectual Property Rights –</b></p> <p>The Supplier shall indemnify the Procuring Entity against all third-party claims of infringement of patent, trademark, or industrial design rights arising from use of the Goods or any part thereof.</p>
2.2	<p>The terms of payment shall be as follows:</p> <p>Partial/Progress payment is not allowed.</p>
4	<p>The inspections and tests that will be conducted are:</p> <p><b>Pump Efficiency Test, Continuous at least 1 hour.</b></p> <p>Inspection and quality tests prior to delivery, and on site prior to acceptance of the Goods.</p> <p><i>Delivery Inspection: Actual Physical test will be done to assess the durability and to verify if the items are defective or not defective.</i></p> <p>Upon notification from the Administrative and General Services Division of Digos Water District that a delivery is made, the Procuring Entity’s Inspectorate Team and End User, and supplier shall randomly inspect goods delivered in conformity to required specifications.</p> <p>If in case a non-compliance to some provisions in the specifications arises, the testing shall be conducted while such discrepancies are to be rectified by the supplier at <b>no cost</b> to the Procuring Entity in not less than thirty (30) calendar days.</p> <p>Otherwise, in case no defect or discrepancy is reported during the delivery inspection, testing will immediately be conducted in accordance to the testing standard stipulated herein.</p>

	All reasonable facilities and assistance for the inspection and testing of Goods, including access to drawings and production data, shall be provided by the Supplier to the authorized inspectors at <b>no charge</b> to the Procuring Entity.
--	---

## *Section VI. Schedule of Requirements*

The delivery schedule expressed as weeks/months stipulates hereafter a delivery date which is the date of delivery to the project site.

Item Number	Description	Quantity	Total	Delivered, Weeks/Months
<b>SUPPLY, DELIVERY, INSTALLATION, TESTING AND COMMISSIONING OF ELECTRO-MECHANICAL EQUIPMENT FOR THE NEW PUMPING STATION AT BRGY. TIGUMAN, DIGOS CITY – 60 Calendar Days)</b>		<b>1 LOT</b>		<b>60 Calendar days</b>
1.	200mm dia., Gate Valve, Temperature range: - 10° C to +70° C. Max 10% solid matter. Insulation essential for temperatures of 0° C and below. Maximum Working Pressure: 16 bar (1.6 MPa) washer, bolt & nut with gaskets.	3 pcs		
2.	200mm dia., Sleeve-Type Coupling with complete harness set (plate min. 15mm) with gaskets.	2 pcs		
3.	200mm dia., X 45 deg Bend Elbow B.I. Sch. 40 with flanges (8 holes and washer, bolts & nuts) with gaskets.	2 pcs.		
4.	200mm dia., TEE, B.I. Sch. 40 with flanges (8 holes for washer, bolts & nuts) with gaskets.	1 pc.		
5.	200mm dia., Check Valve with counter weight washer, bolt & nut with gaskets	1 pc.		
6.	B.I. 150mm dia. X 90 deg. (150mm) Bend Elbow Sch. 40 with Flange, and 150mm length attached to a base plate 12mm thick, down connected to 1 meter B.I. Sch. 40 column pipe with threaded coupling washer, bolts & nuts with gaskets.	1 lump sum		
7.	150mm x 200mm B.I. Sch. 40 coupling reducer with flanges	1 pc.		

	both ends. (8holes) washer, bolts & nuts with gaskets			
8.	200mm dia., Spool pipes Sch. 40 with flanges (ISO 8holes) both end washer, bolts & nuts with gaskets, (depend in the design lay-out) including bypass pipeline (see attached drawing sheet no. 1).	1 lump sum		
9.	150mm dia., B.I. Pipe, threaded both ends, 3m, 7mm thick	19 pcs.		
10.	150mm dia., B.I. Pipe, threaded both ends, 1.5m, 7mm thick	2 pcs.		
11.	150mm dia., B.I. Threaded Coupling, 10mm thick.	24 pcs.		
12.	200mm dia., Flanges with gaskets (8holes for washer, bolts & nuts) for 200mm diameter pipe (spare)	2 pcs		
13.	Fabricated base steel plate with 0.90m x 0.90m x 12mm thick, with center hole diameter of 150mm diameter, (see attached plan)washer, bolt & nut with gaskets	1 pc.		
14.	200mm dia., C.I. M.J. Gate Valve washers, bolts & nuts with gaskets	1 pc.		
15.	200mm dia. B.I. pipe sch. 40 x 6m (spare)	1 pc.		
16.	200mm dia. Transition Coupling, washers, bolts & nuts with gaskets	1 pc.		
17.	200mm, C.I. Coupling, washers, bolts &nuts with gaskets	1 pc.		
18.	200mm x 150mm, C.I. Coupling Reducer washer, bolt & nut with gaskets	1 pc.		
19.	200mm C.I. Tee washers, bolt & nut with gaskets	1 pc.		
20.	Electromagnetic Flow Meter (washer, bolt & nut with gaskets) (AC- Powered Remote Version), DN 200, hard rubber liner, 648 m <sup>3</sup> /h maximum flow., DN200/PN 16,	1 unit		



	<p>remote version size: DN200mm, Cover for Field Cabinet (small) Transparent, PN10 Cable: 15m, sensor: IP68; Body: Carboon Steel, converting housing aluminum coating., Sensing electrodes: Stainless steel (SS316) , Enclosure Rating IP 67, NEMA 6, hasteloy 2 x measuring /1 x indication of empty tube /1 x ground., Communication: RTU-mode, 9600 baud, 2-wire RS 485, master-mode, keyboard, permanently backlit graphical display, SMS via internal GSM Module., Protection: IP68:sensor / IP68: converter (compact version), IP67/68: sensor / IP68: converter (remote version)., Datalogger: built-in 32 MB data logger can log up to 345.000 entries with time and date. Data is displayed graphically, but can also be exported to a PC via the USB port on the Display Unit and can send data to system server located in the office.</p>			
21.	Mechanical Flowmeter 200mm dia. washers, bolts & nuts with gaskets	1 pc.		
22.	Chlorinator, 250 psi pressure capacity, 220V and Installation with straight meter valve and other fittings in the chlorine injection point.	1 lump sum		
23.	Pressure Gauge, 300psi pressure capacity, liquid filled, 3 inches diameter. Water type and installation with straight meter valve and other fittings.	2 lump sum		
24.	50mm dia. Air release Valve threaded and installation, with	1 lump sum		

	straight meter valve and other fittings.			
25.	15mm Brass Faucet with G.I. Installation with straight meter valve and other fittings.» 2 sq. mtrs - Rubber Gasket, 5mm thick(spare)	1 lump sum		
26.	Submersible Motor, 60HP, 460V, 3phase, 'Ins Class F IP68, 'Continuous Duty, FE exclusive SAND FIGHTER sealing system., Subtrol-plus heat sensor equipped., Full 3450 rpm @60hz design point for superior pump head & flow yield., Full rated Hp output at 30 deg. C. Ambient., High temperature winding wire rated 180 deg. C. (365 deg. F)., FE FES91 water soluble fill and bearing lubrication solution is environmentally safe - no oil., FE exclusive Water-Bloc™ connection allows the lead to be replaced in the field., Copper bar rotors provide more consistent performance than other designs; Double flange design increases ease and safety of handling the motor and mounting the pump; Steel/Carbon Kingsbury-type thrust bearings provide the best performance in water lubricated motors; Stainless steel shell provides corrosion resistance.	1 unit		
27.	Submersible Pump with a discharge of minimum 50LPS against a TDH of 65M, 3450rpm., Built in non-return valve, Corrosion Resistant, AISI 304 Stainless steel inside and out. 100% High - grade stainless steel, Wear Resistance, less abrasive wear; Octagonal bearings and	1 unit		

	sand flush channels., Sand Resistance., FKM Rubber parts (elastomer)., Curve Grade 3B standard, ISO 9906:2012.			
28.	Submersible Cable, 50mm <sup>2</sup> , 3 wires, flat & flexible	90 meters		
29.	Royal Cord Type ST, 1.25mm <sup>2</sup>	120 meters		
30.	Splicing Kit for 50mm <sup>2</sup> submersible cable	1 set		
31.	Liquid level sensor rod, part no. 13-022000	2 sets		
32.	Submersible Motor Controller, pre-wired, Softstarter for (75hp submersible motor) min. 125 A, 460V, 3phase, provides simultaneous display of Current, KW, HP, KVA and power factor readings, pre-wired, with complete accessories as; lightning arrester, main breaker, main magnetic contactor, water level sensor relay, over/under voltage protector, delay timer, analogue voltmeter and ammeter and has a manual and automatic mode. (Softstarter = Operating temperature -10° C to 60° C, above 40° C with derating Storage temperature -25° C to + 60° C; Operating altitude 0-1000 m, above 1000 m with derating; Humidity 5% to 95% relative humidity; Pollution degree Pollution Degree 3 Vibration IEC 60068-2-6).	1 set		
33.	Spool B.I. Pipes Sch.40 with flanges, washers, bolts & nuts with gaskets (see attached drawing)	1 lump sum		
34.	Construction and installation of Pump foundation, concrete & discharge pipe supports and steel brackets, Concrete pedestals and Concrete Splash-Box, changes may vary in the actual installation.	1 lump sum		

	(pump & motor cage use only deformed bar/roundbar or Flatbar 12mm).			
35.	Circuit Breaker with factory assembled enclosure, 250A, 3phase	1 pc.		
36.	Copper Wire, THW, 50mm <sup>2</sup>	150 meters		
37.	Copper Wire, THW, 3.5mm <sup>2</sup>	150 meters		
38.	Copper Wire, THW, 2.0mm <sup>2</sup>	150 meters		
39.	Copper Wire, THW, 14mm <sup>2</sup>	70 meters		
40.	Terminal Eye Connector, 38-8	20 pcs.		
41.	Circuit Breaker Panel Board, bolt-on, 4 branches	1 pc.		
42.	Circuit Breaker, bolt-on, 60A	1 pair		
43.	Circuit Breaker, bolt-on, 20A	2 pairs		
44.	Circuit Breaker, bolt-on, 30A	2 pairs		
45.	Convenient outlet, flush type, 2 gang	4 pcs.		
46.	Switch with plate, flush type, 3 gang	2 pcs.		
47.	Bulb holder, plastic	6 pcs.		
48.	Utility Box, 2 x 4, plastic	8 pcs.		
49.	Entrance Cap, 50mm dia.	1 pc.		
50.	Entrance Cap, 25mm dia.	1 pc.		
51.	Coupling G.I., 3/4 inch	4 pcs.		
52.	Coupling G.I., 1 1/4 inch	2 pcs.		
53.	RSC Pipe, 50mm dia.	10 length		
54.	RSC Pipe, 25mm dia.	10 length		
55.	RSC elbow, 50mm dia.	6 pcs.		

56.	RSC Coupling, 50mm dia.	6 pcs.		
57.	RSC Elbow, 25mm dia.	6 pcs.		
58.	RSC coupling, 25mm dia	6 pcs.		
59.	Secondary Rack, 3 phase	1 pc.		
60.	Spool Insulator, Medium size	2 pcs.		
61.	Plane Sheet, G.I., 1.2mm thick	1 pc.		
62.	Tox with metal screw, #8	70 pcs.		
63.	Metal Screw, 5mm x 25mm dia	50 pcs.		
64.	Orifice Plate, 200mm x 150mm dia	1 pc.		
	Note: Spool Pipes with flanges have to be pre-painted with acrylic paint. (Zurich Blue Color)			
	Other Requirements (for Submersible Pump & Motor, Electro-Magnetic Flow Meter, Chlorinator and Sub. Motor Controller:			
	*PNS Certificate (if applicable)			
	*Certificates of Parts Availability and After – Sales Service			
	*Including Testing and Commissioning & Certificates			
	*Latest Calibration Certificates of Electro-magnetic & Mechanical Flow Meter.			
	*PNS 26:1992 / PNS 26:2018 Certificate for B.I. Pipes			
	*Pump & Motor Efficiency Test (atleast 1hr operation)			
	*Warranty Certificate			

## ***Section VII. Technical Specifications***

### **Notes for Preparing the Technical Specifications**

A set of precise and clear specifications is a prerequisite for Bidders to respond realistically and competitively to the requirements of the Procuring Entity without qualifying their Bids. In the context of Competitive Bidding, the specifications (*e.g.* production/delivery schedule, manpower requirements, and after-sales service/parts, descriptions of the lots or items) must be prepared to permit the widest possible competition and, at the same time, present a clear statement of the required standards of workmanship, materials, and performance of the goods and services to be procured. Only if this is done will the objectives of transparency, equity, efficiency, fairness, and economy in procurement be realized, responsiveness of bids be ensured, and the subsequent task of bid evaluation and post-qualification facilitated. The specifications should require that all items, materials and accessories to be included or incorporated in the goods be new, unused, and of the most recent or current models, and that they include or incorporate all recent improvements in design and materials unless otherwise provided in the Contract.

Samples of specifications from previous similar procurements are useful in this respect. The use of metric units is encouraged. Depending on the complexity of the goods and the repetitiveness of the type of procurement, it may be advantageous to standardize the General Technical Specifications and incorporate them in a separate subsection. The General Technical Specifications should cover all classes of workmanship, materials, and equipment commonly involved in manufacturing similar goods. Deletions or addenda should then adapt the General Technical Specifications to the particular procurement.

Care must be taken in drafting specifications to ensure that they are not restrictive. In the specification of standards for equipment, materials, and workmanship, recognized Philippine and international standards should be used as much as possible. Where other particular standards are used, whether national standards or other standards, the specifications should state that equipment, materials, and workmanship that meet other authoritative standards, and which ensure at least a substantially equal quality than the standards mentioned, will also be acceptable. The following clause may be inserted in the Special Conditions of Contract or the Technical Specifications.

#### **Sample Clause: Equivalency of Standards and Codes**

Wherever reference is made in the Technical Specifications to specific standards and codes to be met by the goods and materials to be furnished or tested, the provisions of the latest edition or revision of the relevant standards and codes shall apply, unless otherwise expressly stated in the Contract. Where such standards and codes are national or relate to a particular country or region, other authoritative standards that ensure substantial equivalence to the standards and codes specified will be acceptable.

Reference to brand name and catalogue number should be avoided as far as possible; where unavoidable they should always be followed by the words “*or at least equivalent.*” References to brand names cannot be used when the funding source is the GOP.

Where appropriate, drawings, including site plans as required, may be furnished by the Procuring Entity with the Bidding Documents. Similarly, the Supplier may be requested to provide drawings or samples either with its Bid or for prior review by the Procuring Entity during contract execution.

Bidders are also required, as part of the technical specifications, to complete their statement of compliance demonstrating how the items comply with the specification.

In case of Renewal of Regular and Recurring Services, the Procuring Entity must indicate here the technical requirements for the service provider, which must include the set criteria in the conduct of its performance evaluation.

## Technical Specifications

Item	Specification	Quantity	Statement of Compliance
			<p><i>[Bidders must state here either “Comply” or “Not Comply” against each of the individual parameters of each Specification stating the corresponding performance parameter of the equipment offered. Statements of “Comply” or “Not Comply” must be supported by evidence in a Bidders Bid and cross-referenced to that evidence. Evidence shall be in the form of manufacturer’s un-amended sales literature, unconditional statements of specification and compliance issued by the manufacturer, samples, independent test data etc., as appropriate. A statement that is not supported by evidence or is subsequently found to be contradicted by the evidence presented will render the Bid under evaluation liable for rejection. A statement either in the Bidder's statement of compliance or the supporting evidence that is found to be false either during Bid evaluation, post-qualification or the execution of the Contract may be regarded as fraudulent and render the Bidder or supplier liable for prosecution subject to the applicable laws and issuances.]</i></p>
	<p>LOT A – SUPPLY, DELIVERY, INSTALLATION, TESTING AND COMMISSIONING OF ELECTRO-MECHANICAL EQUIPMENT FOR THE NEW PUMPING STATION AT BRGY. TIGUMAN, DIGOS CITY – 60 Calendar Days)</p>	<p>1 LOT</p>	
<p>1.</p>	<p>200mm dia., Gate Valve, Temperature range: - 10° C to +70° C. Max 10% solid matter. Insulation essential for temperatures of 0° C and below. Maximum Working Pressure: 16 bar</p>	<p>3 pcs</p>	



	(1.6 MPa) washer, bolt & nut with gaskets.		
2.	200mm dia., Sleeve-Type Coupling with complete harness set (plate min. 15mm) with gaskets.	2 pcs	
3.	200mm dia. X 45 deg. Bend Elbow B.I. Sch. 40 with flanges (8 holes and washer, bolts & nuts with gaskets.	2 pcs	
4.	200mm dia., TEE, B.I. Sch. 40 with flanges (8 holes for washer, bolts & nuts) with gaskets.	1 pc.	
5.	200mm dia., Check Valve with counter weight washer, bolt & nut with gaskets	1 pc.	
6.	B.I. 150mm dia. X 90 deg. (150mm) Bend Elbow Sch. 40 with Flange, and 150mm length attached to a base plate 12mm thick, down connected to 1 meter B.I. Sch. 40 column pipe with threaded coupling washer, bolts & nuts with gaskets.	1 lump sum	
7.	150mm x 200mm B.I. Sch. 40 coupling reducer with flanges both ends. (8holes) washer, bolts & nuts with gaskets	1 pc.	
8.	200mm dia., Spool pipes Sch. 40 with flanges (ISO 8holes) both end washer, bolts & nuts with gaskets, (depend in the design layout) including bypass pipeline (see attached drawing sheet no. 1).	1 lump sum	
9.	150mm dia., B.I. Pipe, threaded both ends, 3m, 7mm thick	19 pcs.	
10.	150mm dia., B.I. Pipe, threaded both ends, 1.5m, 7mm thick	2 pcs.	

11.	150mm dia., B.I. Threaded Coupling, 10mm thick.	24 pcs.	
12.	200mm dia., Flanges with gaskets (8holes for washer, bolts & nuts) for 200mm diameter pipe (spare)	2 pcs	
13.	Fabricated base steel plate with 0.90m x 0.90m x 12mm thick, with center hole diameter of 150mm diameter, (see attached plan)washer, bolt & nut with gaskets	1 pc.	
14.	200mm dia., C.I. M.J. Gate Valve washers, bolts, & nuts with gaskets	1 pc.	
15.	200mm dia., C.I. M.J. Gate Valve washers, bolts ,& nuts with gaskets	1 pc.	
16.	200mm dia. Transition Coupling, washers, bolts & nuts with gaskets.	1 pc.	
17.	200mm, C.I. Coupling, washers, bolts & nuts with gaskets	1 pc.	
18.	200mm x 150mm, C.I. Coupling Reducer washer, bolt & nut with gaskets	1 pc.	
19.	200mm C.I. Tee washers, bolt & nut with gaskets	1 pc.	
20.	Electromagnetic Flow Meter (washer, bolt & nut with gaskets) (AC- Powered Remote Version), DN 200, hard rubber liner, 648 m <sup>3</sup> /h maximum flow., DN200/PN 16, remote version size: DN200mm, Cover for Field Cabinet	1 unit	

	<p>(small) Transparent, PN10  Cable: 15m, sensor: IP68;  Body: Carbon Steel,  converting housing  aluminum  coating., Sensing  electrodes: Stainless steel  (SS316) ,  Enclosure Rating IP 67,  NEMA 6, hasteloy 2 x  measuring  /1 x indication of empty  tube /1 x ground.,  Communication: RTU-  mode, 9600 baud, 2-wire  RS 485,  master-mode, keyboard,  permanently backlit  graphical  display, SMS via internal  GSM Module., Protection:  IP68:sensor / IP68:  converter (compact  version),  IP67/68: sensor / IP68:  converter (remote  version).,  Datalogger: built-in 32 MB  data logger can log up to  345.000 entries with time  and date. Data is displayed  graphically, but can also be  exported to a PC via the  USB port on the Display  Unit and can send data to  system server located in the  office</p>		
21.	Mechanical Flowmeter 200mm dia. washers, bolts & nuts with gaskets	1 pc.	
22.	Chlorinator, 250 psi pressure capacity, 220V and Installation with straight meter valve and other fittings in the chlorine injection point.	1 lump sum	

23.	Pressure Gauge, 300psi pressure capacity, liquid filled, 3 inches diameter. Water type and installation with straight meter valve and other fittings.	2 lump sum	
24.	50mm dia. Air release Valve threaded and installation, with straight meter valve and other fittings.	1 lump sum	
25.	15mm Brass Faucet with G.I. Installation with straight meter valve and other fittings.» 2 sq. mtrs - Rubber Gasket, 5mm thick(spare)	1 lump sum	
	Submersible Motor, 75HP, 460V, 3phase, 'Ins Class F IP68, 'Continuous Duty, FE exclusive SAND FIGHTER sealing system., Subtrol-plus heat sensor equipped., Full 3450 rpm @60hz design point for superior pump head & flow yield., Full rated Hp output at 30 deg. C. Ambient., High temperature winding wire rated 180 deg. C. (365 deg. F)., FE FES91 water soluble fill and bearing lubrication solution is environmentally safe - no oil., FE exclusive Water-Bloc™ connection allows the lead to be replaced in the field., Copper bar rotors provide more consistent performance than other designs; Double flange design increases ease and safety of handling the	1 unit	

	motor and mounting the pump; Steel/Carbon Kingsbury-type thrust bearings provide the best performance in water lubricated motors; Stainless steel shell provides corrosion resistance.		
26.	Submersible Pump with a discharge of minimum 60LPS against a TDH of 90M, 3450rpm., Built in non-return valve, Corrosion Resistant, AISI 304 Stainless steel inside and out. 100% High - grade stainless steel, Wear Resistance, less abrasive wear; Octagonal bearings and sand flush channels., Sand Resistance., FKM Rubber parts (elastomer)., Curve Grade 3B standard, ISO 9906:2012	1 unit	
27.	Submersible Cable, 50mm <sup>2</sup> , 3 wires, flat & flexible	90 meters	
28.	» 120 meters - Royal Cord Type ST, 1.25mm <sup>2</sup>	120 meters	
29.	Splicing Kit for 50mm <sup>2</sup> submersible cable	1 set	
30.	Liquid level sensor rod, part no. 13-022000	2 sets	
31.	Submersible Motor Controller, pre-wired, Softstarter for (75hp submersible motor) min. 125 A, 460V, 3phase, provides simultaneous display of Current, KW, HP, KVA and power factor readings , pre-wired, with complete accessories as; lightning arrester, main breaker, main magnetic contactor, water level	1 set	

	sensor relay, over/under voltage protector, delay timer, analogue voltmeter and ammeter and has a manual and automatic mode. (Sofstarter = Operating temperature -10° C to 60° C, above 40° C with derating Storage temperature -25° C to + 60° C; Operating altitude 0-1000 m, above 1000 m with derating; Humidity 5% to 95% relative humidity; Pollution degree Pollution Degree 3 Vibration IEC 60068-2-6).		
32.	Spool B.I. Pipes Sch.40 with flanges, washers, bolts & nuts with gaskets (see attached drawing)	1 lump sum	
33.	Construction and installation of Pump foundation, concrete & discharge pipe supports and steel brackets, Concrete pedestals and Concrete Splash-Box, changes may vary in the actual installation. (pump & motor cage use only deformed bar/roundbar or Flatbar 12mm).	1 lump sum	
34.	» 1 pc. - Circuit Breaker with factory assembled enclosure, 250A, 3phase	1 pc.	
35.	» 150 meters - Copper Wire, THW, 50mm <sup>2</sup>	150 meters	
36.	Copper Wire, THW, 3.5mm <sup>2</sup>	150 meters	
37.	Copper Wire, THW, 2.0mm <sup>2</sup>	150 meters	
38.	Copper Wire, THW, 14mm <sup>2</sup>	70 meters	

39.	Terminal Eye Connector, 38-8	20 pcs.	
40.	Circuit Breaker Panel Board, bolt-on, 4 branches	1 pc.	
41.	Circuit Breaker, bolt-on, 60A	1 pair	
42.	Circuit Breaker, bolt-on, 20A	2 pairs	
43.	Circuit Breaker, bolt-on, 30A	2 pairs	
44.	Convenient outlet, flush type, 2 gang	4 pcs.	
45.	Switch with plate, flush type, 3 gang	2 pcs.	
46.	Bulb holder, plastic	6 pcs.	
47.	Utility Box, 2 x 4, plastic	8 pcs.	
48.	Entrance Cap, 50mm dia.	1 pc.	
49.	Entrance Cap, 25mm dia.	1 pc.	
50.	Coupling G.I., 3/4 inch	4 pcs.	
51.	Coupling G.I., 1 1/4 inch	2 pcs.	
52.	RSC Pipe, 50mm dia.	10 length	
53.	RSC Pipe, 25mm dia.	10 length	
54.	RSC elbow, 50mm dia.	6 pcs.	
55.	RSC Coupling, 50mm dia.	6 pcs.	
56.	RSC Elbow, 25mm dia.	6 pcs.	
57.	RSC coupling, 25mm dia.	6 pcs.	
58.	Secondary Rack, 3 phase	1 pc.	
59.	Spool Insulator, Medium size	2 pcs.	
60.	Plane Sheet, G.I., 1.2mm thick	1 pc.	
62.	Tox with metal screw, #8	70 pcs.	

63.	Metal Screw, 5mm x 25mm dia.	50 pcs.	
64.	Orifice Plate, 200mm x 150mm dia.	1 pc.	
	Note: Spool Pipes with flanges have to be pre-painted with acrylic paint. (Zurich Blue Color)		
	Other Requirements (for Submersible Pump & Motor, Electro-Magnetic Flow Meter, Chlorinator and Sub. Motor Controller:		
	*PNS Certificate (if applicable).		
	*Certificates of Parts Availability and After - Sales Service		
	*Including Testing and Commissioning & Certificates		
	*Latest Calibration Certificates of Electro-magnetic & Mechanical Flow Meter.		
	*PNS 26:1992 / PNS 26:2018 Certificate for B.I. Pipes		
	*Pump & Motor Efficiency Test (atleast 1hr operation)		
	*Warranty Certificate		



# DRAWINGS FOR BRGY. TIGUMAN, DIGOS CITY

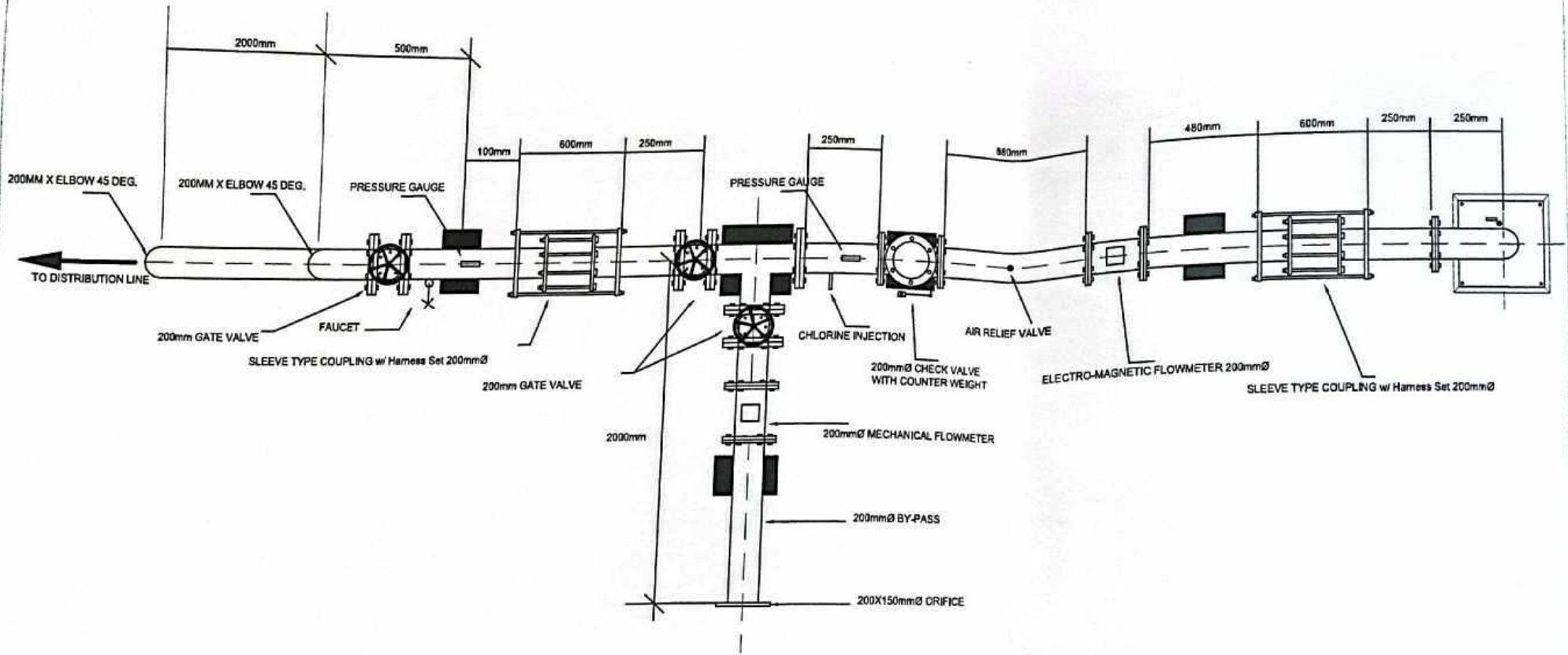

⊙ PUMPING STATION STRUCTURE  
NOT TO SCALE

PREPARED BY: *[Signature]*  
ENGR. MICHAEL JR. A. CALAPAN  
WRFO - FOREMAN

CHECKED BY: *[Signature]*  
AILEEN R. BANOGBANOG  
DIV. MANAGER, WATER RESOURCES

PROJECT TITLE:  
ELECTROMECHANICAL EQUIPMENT  
LOCATION: BRGY. TIGUMAN, DIGOS CITY, DAVAO DEL SUR

APPROVED BY: *[Signature]*  
ENSR. FRANKLIN S. RETES, PH.D.  
ACTING GENERAL MANAGER

SHEET NO.  
1

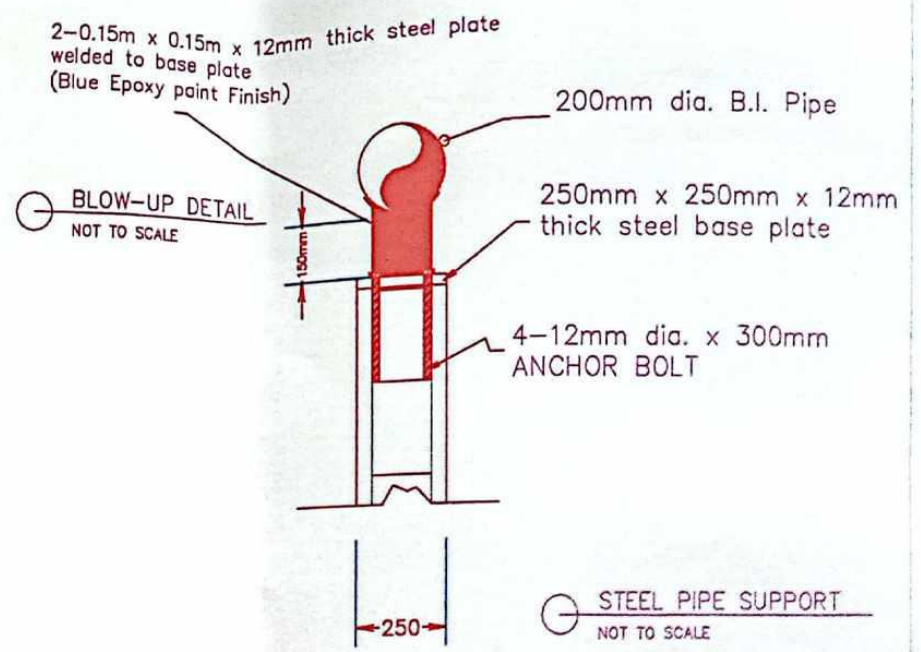
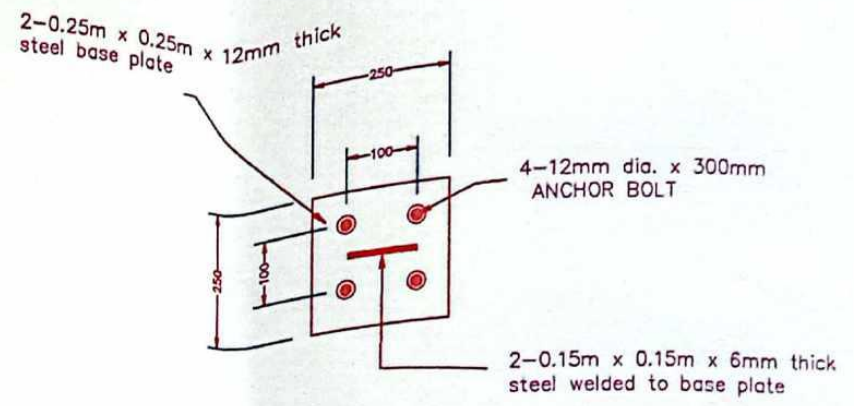
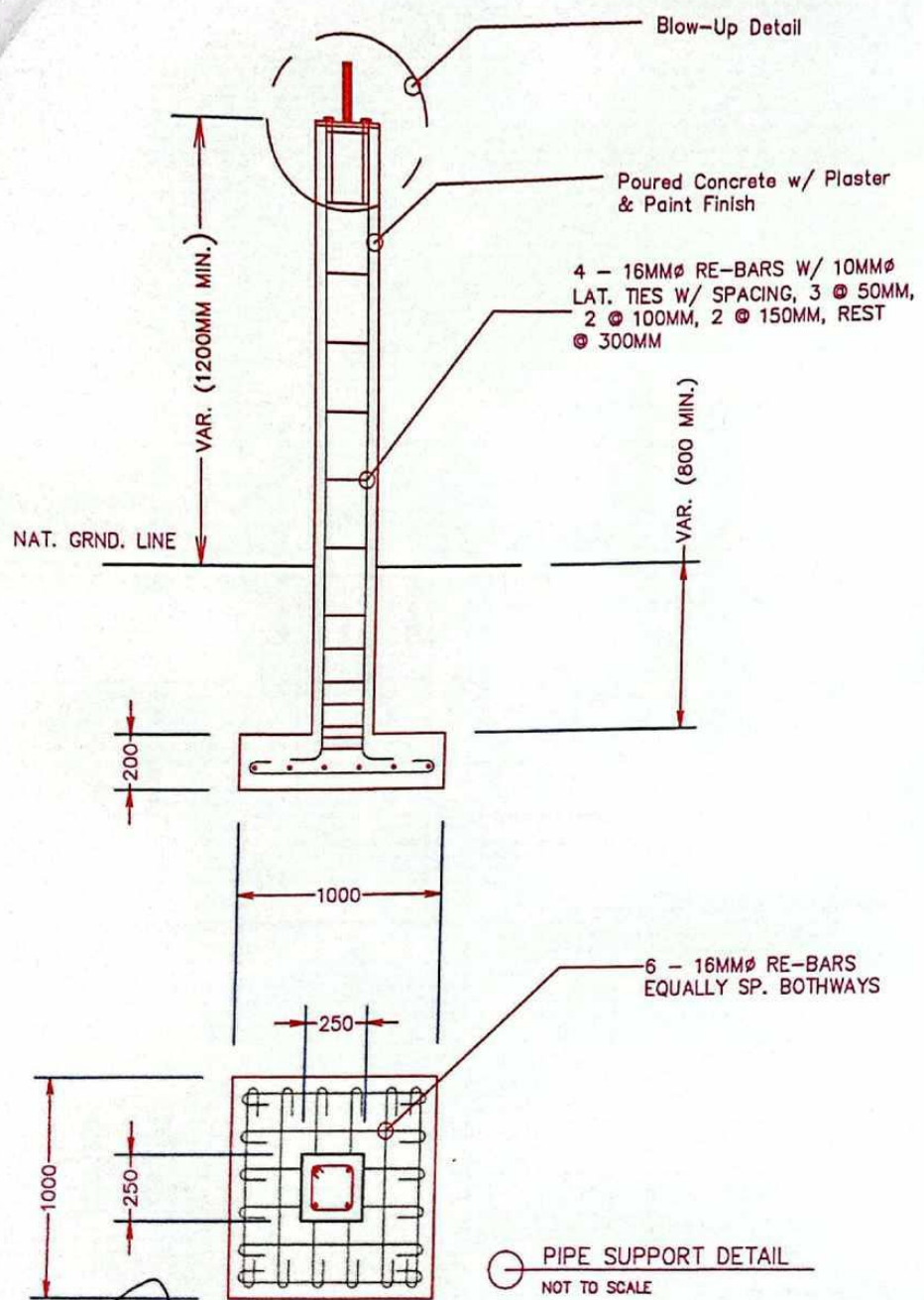

PREPARED BY:   
 ENGR. MICHAEL J. A. CALAPAN  
 WRFO - FOREMAN

CHECKED & VERIFIED BY:   
 AILEEN R. BANOGBANOG  
 DIV. MANAGER, WATER RESOURCES

PROJECT TITLE:  
 ELECTROMECHANICAL EQUIPMENT  
 LOCATION: BRGY. TIGUMAN, DIGOS CITY, DAVAO DEL SUR

APPROVED BY:   
 ENGR. FRANKLIN S. PETES, PH.D.  
 ACTING GENERAL MANAGER

SHEET NO.  
 2



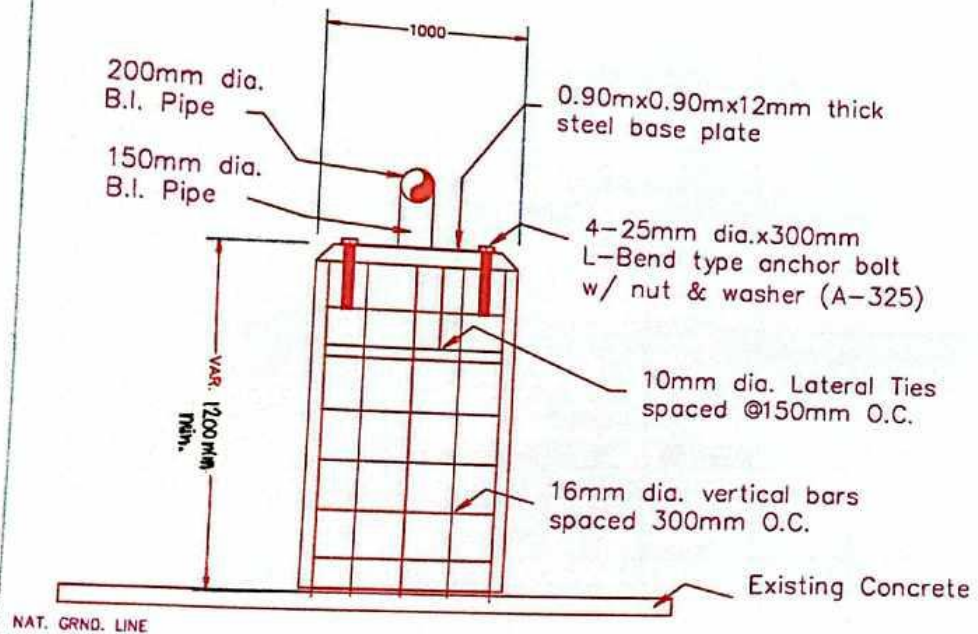

⊙ SUBMERSIBLE PUMP CONCRETE PEDESTAL W/ FULLY PLASTERED FINISH  
NOT TO SCALE

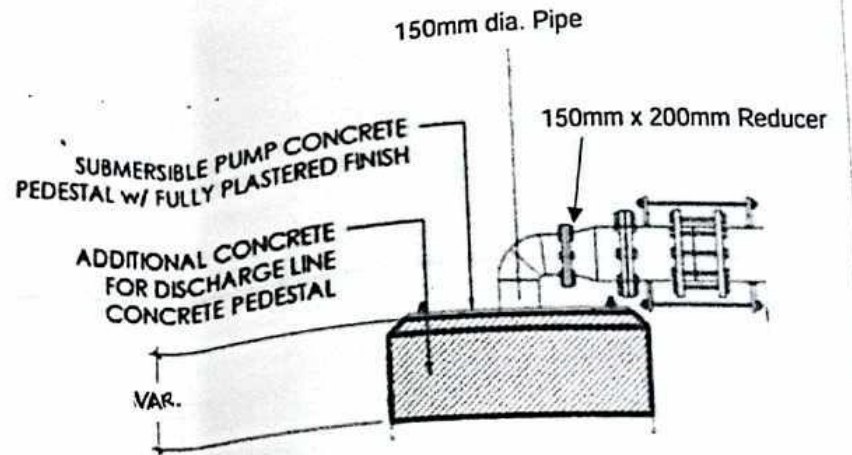

⊙ PUMP PEDESTAL W/ FULLY PLASTERED FINISH  
NOT TO SCALE

PREPARED BY:

ENGR. MICHAEL JR. A. GALAPAN  
WRFO - FOREMAN

CHECKED BY:

AILEEN R. BANOGBANOG  
DIV. MANAGER, WATER RESOURCES

PROJECT TITLE:

ELECTROMECHANICAL EQUIPMENT  
LOCATION: BRGY. TIGUMAN, DIGOS CITY, DAVAO DEL SUR

APPROVED BY:

ENGR. FRANKLIN S. PETES, PH.D.  
ACTING GENERAL MANAGER

SHEET NO.

3

500mm

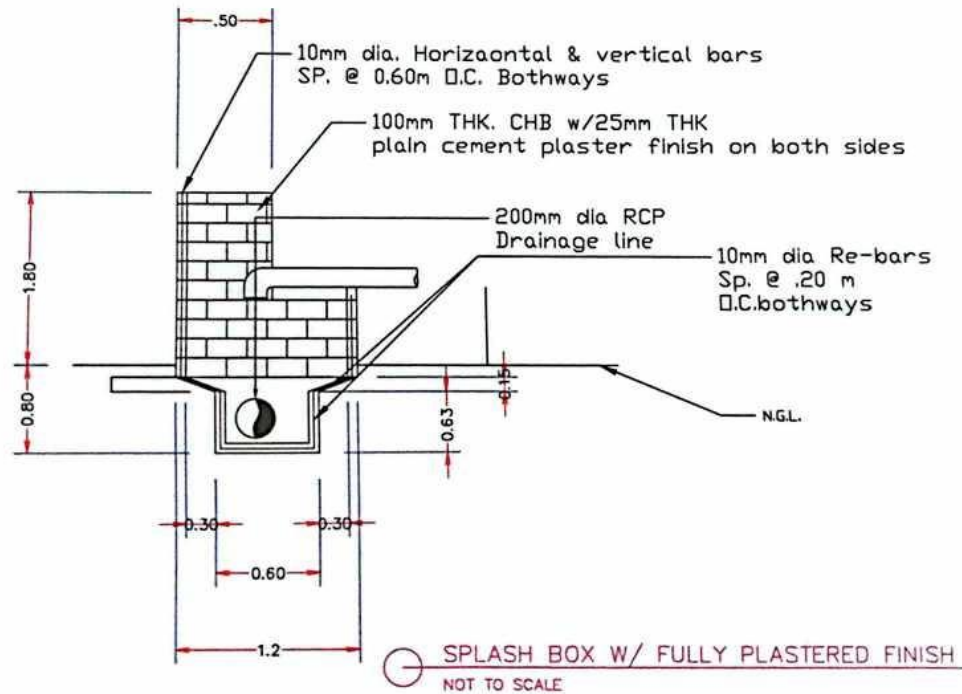
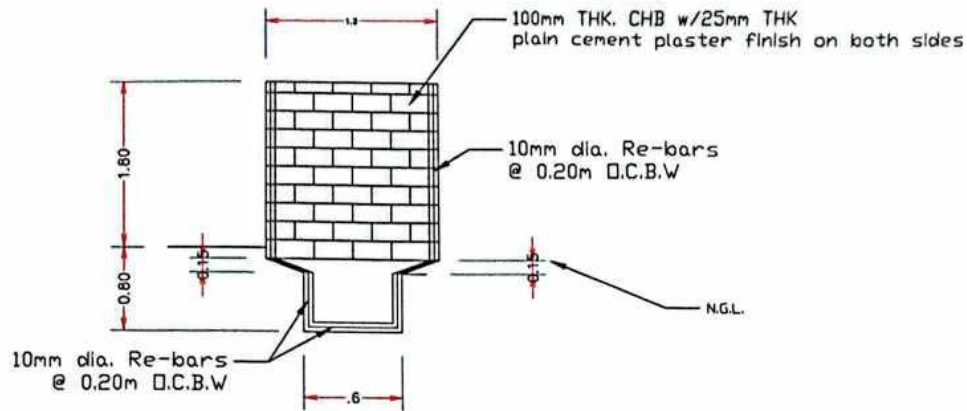

PREPARED BY:  
*Michael R. A. Calapan*  
ENGR. MICHAEL R. A. CALAPAN  
WRFO - FOREMAN

CHECKED BY:  
*Aileen R. Banogbanog*  
AILEEN R. BANOGBANOG  
DIV. MANAGER, WATER RESOURCES

PROJECT TITLE:  
SPLASH BOX DETAILS  
LOCATION: PUROK BOMBELL, TIGUMAN, DIGOS CITY

APPROVED BY:  
*Aileen R. Banogbanog*  
AILEEN R. BANOGBANOG  
ENGR. FRANKLIN S RETES PH.D.  
ACTING GENERAL MANAGER

SHEET NO.

1





Republic of the Philippines  
Department of Environment and Natural Resources  
**NATIONAL WATER RESOURCES BOARD**  
8<sup>th</sup> Floor NIA Bldg., EDSA, Diliman, Quezon City, Philippines 1100

## CONDITIONAL WATER PERMIT

CWP No. 05-24-24-017

<p>1. The Permittee with indicated mailing address</p> <p><b>Digos Water District</b> <b>Rizal Avenue, Zone II, Digos City,</b> <b>Davao del Sur</b></p>	<p>2. is hereby granted permit to use water from the source known as <b>Deepwell</b></p> <p>by diverting the water by means of <b>Pump</b></p>
<p>3. with the diversion point located at Place : <b>Purok Bombell, Tiguman, Digos City,</b> <b>Davao del Sur (SA DDS 2-2551)</b></p> <p>Latitude: <b>06° 45' 31.04" N</b></p> <p>Longitude: <b>125° 19' 17.15" E</b></p>	<p>4. in an amount, in liters per second, not exceeding <b>14.5 liters per second</b></p> <p>during the month of <b>January to December</b></p>
<p>5. for the purpose of <b>Municipal</b></p>	
<p>6. This Conditional Water Permit shall be valid for one (1) year, unless sooner revoked or cancelled by the Board. A water permit shall be issued by the Board upon proof submitted by the Permittee showing compliance with the foregoing conditions:</p> <ul style="list-style-type: none"> <li>• Upon receipt of a copy of the Conditional Water Permit, the Permittee shall manifest in writing his acceptance thereof with all its terms and conditions.</li> <li>• Within one (1) year from date hereof, the grantee shall: <ul style="list-style-type: none"> <li>a. Submit a copy of the plans and specifications for the diversion works, pump structure, water measuring device and water distribution system.</li> </ul> </li> <li>• The Permittee shall install and maintain water control and measuring devices to monitor water level and releases/extraction and water meters duly tested and sealed by the National Water Resources Board and keep monthly records of water withdrawals to be submitted to the Board on a quarterly basis.</li> </ul>	
<p>7. the Permittee shall pay an annual water charge in the amount of</p> <p>which shall be payable and remitted by Philippine Postal Money Order or check to the NATIONAL WATER RESOURCES BOARD</p> <p>8. This CWP will expire on: <b>May 24, 2025</b></p>	<p>Given on this date: <b>May 24, 2024</b></p> <p><b>By authority of the Board per Res. No. 13-0923</b></p> <p></p> <p><b>ATTY. RICKY A. ARZADON, CESO IV</b> OIC, Executive Director</p>





NATIONAL WATER RESOURCES BOARD  
8<sup>th</sup> Floor, NIA Bldg., EDSA, QUEZON CITY  
Tel. No. 920-26-03; 920-26-54 Fax 920-27-24

May 27, 2024

**Digos Water District**  
**c/o Engr. Felomino A. Daub, PME**  
Rizal Avenue, Zone II, Digos City,  
Davao del Sur

Sir/Madam:

We are pleased to transmit herewith your Conditional Water Permit.

Please be informed that failure on your part to submit the required plans and specifications as well as non-compliance with other conditions imposed in your Conditional Water Permit will constitute sufficient grounds for the non-issuance of your Water Permit.

Your cooperation hereon will be highly appreciated.

Very truly yours,

  
**ATTY. RICKY A. ARZADON, CESO IV**  
OIC, Executive Director

Encl.  
Conditional Water Permit No. **05-24-24-017**  
Deepwell  
Lat.: 06° 45' 31.04" N  
Long.: 125° 19' 17.15" E  
14.5 liters per second

## ***Section VIII. Checklist of Technical and Financial Documents***

### **Notes on the Checklist of Technical and Financial Documents**

The prescribed documents in the checklist are mandatory to be submitted in the Bid, but shall be subject to the following:

- a. GPPB Resolution No. 09-2020 on the efficient procurement measures during a State of Calamity or other similar issuances that shall allow the use of alternate documents in lieu of the mandated requirements; or
- b. Any subsequent GPPB issuances adjusting the documentary requirements after the effectivity of the adoption of the PBDs.

The BAC shall be checking the submitted documents of each Bidder against this checklist to ascertain if they are all present, using a non-discretionary “pass/fail” criterion pursuant to Section 30 of the 2016 revised IRR of RA No. 9184.

# Checklist of Technical and Financial Documents

## I. TECHNICAL COMPONENT ENVELOPE

### *Class "A" Documents*

#### Legal Documents

- (a) Valid PhilGEPS Registration Certificate (Platinum Membership) (all pages) **in accordance with Section 8.5.2 of the IRR;**

#### Technical Documents

- (b) Statement of the prospective bidder of all its ongoing government and private contracts, including contracts awarded but not yet started, if any, whether similar or not similar in nature and complexity to the contract to be bid; **and**
- (c) Statement of the bidder's Single Largest Completed Contract (SLCC) similar to the contract to be bid, except under conditions provided for in Sections 23.4.1.3 and 23.4.2.4 of the 2016 revised IRR of RA No. 9184, within the relevant period as provided in the Bidding Documents; **and**
- (d) Original copy of Bid Security. If in the form of a Surety Bond, submit also a certification issued by the Insurance Commission **or** Original copy of Notarized Bid Securing Declaration; **and**
- (e) Conformity with the Technical Specifications, which may include production/delivery schedule, manpower requirements, and/or after-sales/parts, if applicable; **and**
- (f) Original duly signed Omnibus Sworn Statement (OSS) **and** if applicable, Original Notarized Secretary's Certificate in case of a corporation, partnership, or cooperative; or Original Special Power of Attorney of all members of the joint venture giving full power and authority to its officer to sign the OSS and do acts to represent the Bidder.

#### Financial Documents

- (g) The prospective bidder's computation of Net Financial Contracting Capacity (NFCC) **or** A committed Line of Credit from a Universal or Commercial Bank in lieu of its NFCC computation.

### *Class "B" Documents*

- (h) If applicable, a duly signed joint venture agreement (JVA) in case the joint venture is already in existence **or** duly notarized statements from all the potential joint venture partners stating that they will enter into and abide by the provisions of the JVA in the instance that the bid is successful.

## II. FINANCIAL COMPONENT ENVELOPE

- (i) Original of duly signed and accomplished Financial Bid Form; **and**
- (j) Original of duly signed and accomplished Price Schedule(s).

#### Other documentary requirements under RA No. 9184 (as applicable)

- (k) [For foreign bidders claiming by reason of their country's extension of reciprocal rights to Filipinos] Certification from the relevant government office of their country stating that Filipinos are allowed to participate in



- government procurement activities for the same item or product.
- (1) Certification from the DTI if the Bidder claims preference as a Domestic Bidder or Domestic Entity.

# Bidding Forms

- I. Bid Form for the Procurement of Goods
- II. Price Schedule
- III. Bid Securing Declaration Form
- IV. Omnibus Sworn Statement
- V. Performance Securing Declaration
- VI. Contract Agreement Form for the Procurement of Goods
- VII. Statement of the Bidder of all its Ongoing Government and Private Contracts, including Contracts Awarded but Not Yet Started
- VIII. Statement of the Bidder's Single Largest and Completed Contract Similar to the Contract to be Bid

**Bid Form for the Procurement of Goods**  
*[shall be submitted with the Bid]*

---

**BID FORM**

Date : \_\_\_\_\_  
 Project Identification No. : \_\_\_\_\_

To: *[name and address of Procuring Entity]*

Having examined the Philippine Bidding Documents (PBDs) including the Supplemental or Bid Bulletin Numbers *[insert numbers]*, the receipt of which is hereby duly acknowledged, we, the undersigned, offer to *[supply/deliver/perform]* *[description of the Goods]* in conformity with the said PBDs for the sum of *[total Bid amount in words and figures]* or the total calculated bid price, as evaluated and corrected for computational errors, and other bid modifications in accordance with the Price Schedules attached herewith and made part of this Bid. The total bid price includes the cost of all taxes, such as, but not limited to: *[specify the applicable taxes, e.g. (i) value added tax (VAT), (ii) income tax, (iii) local taxes, and (iv) other fiscal levies and duties]*, which are itemized herein or in the Price Schedules,

If our Bid is accepted, we undertake:

- a. to deliver the goods in accordance with the delivery schedule specified in the Schedule of Requirements of the Philippine Bidding Documents (PBDs);
- b. to provide a performance security in the form, amounts, and within the times prescribed in the PBDs;
- c. to abide by the Bid Validity Period specified in the PBDs and it shall remain binding upon us at any time before the expiration of that period.

*[Insert this paragraph if Foreign-Assisted Project with the Development Partner:*

Commissions or gratuities, if any, paid or to be paid by us to agents relating to this Bid, and to contract execution if we are awarded the contract, are listed below:

Name and address of agent	Amount	Purpose of Commission or gratuity
---------------------------	--------	-----------------------------------

(if none, state “None”) ]

Until a formal Contract is prepared and executed, this Bid, together with your written acceptance thereof and your Notice of Award, shall be binding upon us.

We understand that you are not bound to accept the Lowest Calculated Bid or any Bid you may receive.

We certify/confirm that we comply with the eligibility requirements pursuant to the PBDs.

The undersigned is authorized to submit the bid on behalf of *[name of the bidder]* as evidenced by the attached *[state the written authority]*.

We acknowledge that failure to sign each and every page of this Bid Form, including the attached Schedule of Prices, shall be a ground for the rejection of our bid.

Name: \_\_\_\_\_

Legal capacity: \_\_\_\_\_

Signature: \_\_\_\_\_

Duly authorized to sign the Bid for and behalf of: \_\_\_\_\_

Date: \_\_\_\_\_

**Price Schedule for Goods Offered from Within the Philippines**  
*[shall be submitted with the Bid if bidder is offering goods from within the Philippines]*

**For Goods Offered from Within the Philippines**

Name of Bidder \_\_\_\_\_ Project ID No. \_\_\_\_\_ Page \_\_\_ of \_\_\_

1	2	3	4	5	6	7	8	9	10
Item	Description	Country of origin	Quantity	Unit price EXW per item	Transportation and all other costs incidental to delivery, per item	Sales and other taxes payable if Contract is awarded, per item	Cost of Incidental Services, if applicable, per item	Total Price, per unit  (col 5+6+7+8)	Total Price delivered Final Destination  (col 9) x (col 4)

Name: \_\_\_\_\_

Legal Capacity: \_\_\_\_\_

Signature: \_\_\_\_\_

Duly authorized to sign the Bid for and behalf of: \_\_\_\_\_

## Price Schedule for Goods Offered from Abroad

*[shall be submitted with the Bid if bidder is offering goods from Abroad]*

### *For Goods Offered from Abroad*

Name of Bidder \_\_\_\_\_ Project ID No. \_\_\_\_\_ Page \_\_\_ of \_\_\_

1	2	3	4	5	6	7	8	9
Item	Description	Country of origin	Quantity	Unit price CIF port of entry (specify port) or CIP named place  (specify border point or place of destination)	Total CIF or CIP price per item  (col. 4 x 5)	Unit Price Delivered Duty Unpaid (DDU)	Unit price Delivered Duty Paid (DDP)	Total Price delivered DDP (col 4 x 8)

Name: \_\_\_\_\_

Legal Capacity: \_\_\_\_\_

Signature: \_\_\_\_\_

Duly authorized to sign the Bid for and behalf of: \_\_\_\_\_

## **Bid Securing Declaration Form**

*[shall be submitted with the Bid if bidder opts to provide this form of bid security]*

---

REPUBLIC OF THE PHILIPPINES)  
CITY OF \_\_\_\_\_) S.S.

### **BID SECURING DECLARATION** **Project Identification No.: *[Insert number]***

To: *[Insert name and address of the Procuring Entity]*

I/We, the undersigned, declare that:

1. I/We understand that, according to your conditions, bids must be supported by a Bid Security, which may be in the form of a Bid Securing Declaration.
2. I/We accept that: (a) I/we will be automatically disqualified from bidding for any procurement contract with any procuring entity for a period of two (2) years upon receipt of your Blacklisting Order; and, (b) I/we will pay the applicable fine provided under Section 6 of the Guidelines on the Use of Bid Securing Declaration, within fifteen (15) days from receipt of the written demand by the procuring entity for the commission of acts resulting to the enforcement of the bid securing declaration under Sections 23.1(b), 34.2, 40.1 and 69.1, except 69.1(f), of the IRR of RA No. 9184; without prejudice to other legal action the government may undertake.
3. I/We understand that this Bid Securing Declaration shall cease to be valid on the following circumstances:
  - a. Upon expiration of the bid validity period, or any extension thereof pursuant to your request;
  - b. I am/we are declared ineligible or post-disqualified upon receipt of your notice to such effect, and (i) I/we failed to timely file a request for reconsideration or (ii) I/we filed a waiver to avail of said right; and
  - c. I am/we are declared the bidder with the Lowest Calculated Responsive Bid, and I/we have furnished the performance security and signed the Contract.

IN WITNESS WHEREOF, I/We have hereunto set my/our hand/s this \_\_\_\_ day of *[month]* *[year]* at *[place of execution]*.

*[Insert NAME OF BIDDER OR ITS AUTHORIZED  
REPRESENTATIVE]*

*[Insert signatory's legal capacity]*

Affiant

**[Jurat]**

*[Format shall be based on the latest Rules on Notarial Practice]*

## Omnibus Sworn Statement (Revised)

*[shall be submitted with the Bid]*

---

REPUBLIC OF THE PHILIPPINES )  
CITY/MUNICIPALITY OF \_\_\_\_\_ ) S.S.

### AFFIDAVIT

I, [Name of Affiant], of legal age, [Civil Status], [Nationality], and residing at [Address of Affiant], after having been duly sworn in accordance with law, do hereby depose and state that:

1. *[Select one, delete the other:]*

*[If a sole proprietorship:]* I am the sole proprietor or authorized representative of [Name of Bidder] with office address at [address of Bidder];

*[If a partnership, corporation, cooperative, or joint venture:]* I am the duly authorized and designated representative of [Name of Bidder] with office address at [address of Bidder];

2. *[Select one, delete the other:]*

*[If a sole proprietorship:]* As the owner and sole proprietor, or authorized representative of [Name of Bidder], I have full power and authority to do, execute and perform any and all acts necessary to participate, submit the bid, and to sign and execute the ensuing contract for [Name of the Project] of the [Name of the Procuring Entity], as shown in the attached duly notarized Special Power of Attorney;

*[If a partnership, corporation, cooperative, or joint venture:]* I am granted full power and authority to do, execute and perform any and all acts necessary to participate, submit the bid, and to sign and execute the ensuing contract for [Name of the Project] of the [Name of the Procuring Entity], as shown in the attached [state title of attached document showing proof of authorization (e.g., duly notarized Secretary's Certificate, Board/Partnership Resolution, or Special Power of Attorney, whichever is applicable)];

3. [Name of Bidder] is not "blacklisted" or barred from bidding by the Government of the Philippines or any of its agencies, offices, corporations, or Local Government Units, foreign government/foreign or international financing institution whose blacklisting rules have been recognized by the Government Procurement Policy Board, **by itself or by relation, membership, association, affiliation, or controlling interest with another blacklisted person or entity as defined and provided for in the Uniform Guidelines on Blacklisting;**

4. Each of the documents submitted in satisfaction of the bidding requirements is an authentic copy of the original, complete, and all statements and information provided therein are true and correct;

5. [Name of Bidder] is authorizing the Head of the Procuring Entity or its duly authorized representative(s) to verify all the documents submitted;

6. *[Select one, delete the rest:]*



*[If a sole proprietorship:]* The owner or sole proprietor is not related to the Head of the Procuring Entity, Procurement Agent if engaged, members of the Bids and Awards Committee (BAC), the Technical Working Group, and the BAC Secretariat, the head of the Project Management Office or the end-user unit, and the project consultants by consanguinity or affinity up to the third civil degree;

*[If a partnership or cooperative:]* None of the officers and members of *[Name of Bidder]* is related to the Head of the Procuring Entity, Procurement Agent if engaged, members of the Bids and Awards Committee (BAC), the Technical Working Group, and the BAC Secretariat, the head of the Project Management Office or the end-user unit, and the project consultants by consanguinity or affinity up to the third civil degree;

*[If a corporation or joint venture:]* None of the officers, directors, and controlling stockholders of *[Name of Bidder]* is related to the Head of the Procuring Entity, Procurement Agent if engaged, members of the Bids and Awards Committee (BAC), the Technical Working Group, and the BAC Secretariat, the head of the Project Management Office or the end-user unit, and the project consultants by consanguinity or affinity up to the third civil degree;

7. *[Name of Bidder]* complies with existing labor laws and standards; and
8. *[Name of Bidder]* is aware of and has undertaken the responsibilities as a Bidder in compliance with the Philippine Bidding Documents, which includes:
  - a. Carefully examining all of the Bidding Documents;
  - b. Acknowledging all conditions, local or otherwise, affecting the implementation of the Contract;
  - c. Making an estimate of the facilities available and needed for the contract to be bid, if any; and
  - d. Inquiring or securing Supplemental/Bid Bulletin(s) issued for the *[Name of the Project]*.
9. *[Name of Bidder]* did not give or pay directly or indirectly, any commission, amount, fee, or any form of consideration, pecuniary or otherwise, to any person or official, personnel or representative of the government in relation to any procurement project or activity.
10. **In case advance payment was made or given, failure to perform or deliver any of the obligations and undertakings in the contract shall be sufficient grounds to constitute criminal liability for Swindling (Estafa) or the commission of fraud with unfaithfulness or abuse of confidence through misappropriating or converting any payment received by a person or entity under an obligation involving the duty to deliver certain goods or services, to the prejudice of the public and the government of the Philippines pursuant to Article 315 of Act No. 3815 s. 1930, as amended, or the Revised Penal Code.**

IN WITNESS WHEREOF, I have hereunto set my hand this \_\_\_ day of \_\_\_, 20\_\_ at \_\_\_\_\_, Philippines.

*[Insert NAME OF BIDDER OR ITS AUTHORIZED REPRESENTATIVE]*

*[Insert signatory's legal capacity]*

Affiant

**[Jurat]**

*[Format shall be based on the latest Rules on Notarial Practice]*

**Performance Securing Declaration (Revised)**

*[if used as an alternative performance security but it is not required to be submitted with the Bid, as it shall be submitted within ten (10) days after receiving the Notice of Award]*

---

REPUBLIC OF THE PHILIPPINES)  
CITY OF \_\_\_\_\_ ) S.S.

**PERFORMANCE SECURING DECLARATION**

Invitation to Bid: [Insert Reference Number indicated in the Bidding Documents]  
To: [Insert name and address of the Procuring Entity]

I/We, the undersigned, declare that:

1. I/We understand that, according to your conditions, to guarantee the faithful performance by the supplier/distributor/manufacturer/contractor/consultant of its obligations under the Contract, I/we shall submit a Performance Securing Declaration within a maximum period of ten (10) calendar days from the receipt of the Notice of Award prior to the signing of the Contract.
2. I/We accept that: I/we will be automatically disqualified from bidding for any procurement contract with any procuring entity for a period of one (1) year for the first offense, or two (2) years **for the second offense**, upon receipt of your Blacklisting Order if I/We have violated my/our obligations under the Contract;
3. I/We understand that this Performance Securing Declaration shall cease to be valid upon:
  - a. issuance by the Procuring Entity of the Certificate of Final Acceptance, subject to the following conditions:
    - i. Procuring Entity has no claims filed against the contract awardee;
    - ii. It has no claims for labor and materials filed against the contractor; and
    - iii. Other terms of the contract; or
  - b. replacement by the winning bidder of the submitted PSD with a performance security in any of the prescribed forms under Section 39.2
  - c. of the 2016 revised IRR of RA No. 9184 as required by the end-user.

**IN WITNESS WHEREOF**, I/We have hereunto set my/our hand/s this \_\_\_\_ day of [month] [year] at [place of execution].

*[Insert NAME OF BIDDER OR ITS  
AUTHORIZED REPRESENTATIVE]  
[Insert signatory's legal capacity]  
Affiant*

**[Jurat]**

*[Format shall be based on the latest Rules on Notarial Practice]*

## Contract Agreement Form for the Procurement of Goods (Revised)

[Not required to be submitted with the Bid, but it shall be submitted within ten (10) days after receiving the Notice of Award]

---

### CONTRACT AGREEMENT

THIS AGREEMENT made the \_\_\_\_\_ day of \_\_\_\_\_ 20\_\_\_\_ between [name of PROCURING ENTITY] of the Philippines (hereinafter called “the Entity”) of the one part and [name of Supplier] of [city and country of Supplier] (hereinafter called “the Supplier”) of the other part;

WHEREAS, the Entity invited Bids for certain goods and ancillary services, particularly [brief description of goods and services] and has accepted a Bid by the Supplier for the supply of those goods and services in the sum of [*contract price in words and figures in specified currency*] (hereinafter called “the Contract Price”).

#### NOW THIS AGREEMENT WITNESSETH AS FOLLOWS:

1. In this Agreement words and expressions shall have the same meanings as are respectively assigned to them in the Conditions of Contract referred to.
2. The following documents as required by the 2016 revised Implementing Rules and Regulations of Republic Act No. 9184 shall be deemed to form and be read and construed as integral part of this Agreement, *viz.*:
  - i. Philippine Bidding Documents (PBDs);
    - i. Schedule of Requirements;
    - ii. Technical Specifications;
    - iii. General and Special Conditions of Contract; and
    - iv. Supplemental or Bid Bulletins, if any
  - ii. Winning bidder’s bid, including the Eligibility requirements, Technical and Financial Proposals, and all other documents or statements submitted;  
  
Bid form, including all the documents/statements contained in the Bidder’s bidding envelopes, as annexes, and all other documents submitted (*e.g.*, Bidder’s response to request for clarifications on the bid), including corrections to the bid, if any, resulting from the Procuring Entity’s bid evaluation;
  - iii. Performance Security;
  - iv. Notice of Award of Contract; and the Bidder’s conforme thereto; and
  - v. Other contract documents that may be required by existing laws and/or the Procuring Entity concerned in the PBDs. **Winning bidder agrees that additional contract documents or information prescribed by the GPPB that are subsequently required for submission after the contract execution, such as the Notice to Proceed, Variation Orders, and Warranty Security, shall likewise form part of the Contract.**

3. In consideration for the sum of *[total contract price in words and figures]* or such other sums as may be ascertained, *[Named of the bidder]* agrees to *[state the object of the contract]* in accordance with his/her/its Bid.
4. The *[Name of the procuring entity]* agrees to pay the above-mentioned sum in accordance with the terms of the Bidding.

IN WITNESS whereof the parties hereto have caused this Agreement to be executed in accordance with the laws of the Republic of the Philippines on the day and year first above written.

*[Insert Name and Signature]*

*[Insert Name and Signature]*

*[Insert Signatory's Legal Capacity]*

*[Insert Signatory's Legal Capacity]*

*for:*

*for:*

*[Insert Procuring Entity]*

*[Insert Name of Supplier]*

**Acknowledgment**

*[Format shall be based on the latest Rules on Notarial Practice]*



Procuring Entity: **DIGOS WATER DISTRICT**

Name of the Project: \_\_\_\_\_

**Statement of Single Largest Completed Contracts (SLCC) Similar to the Contract to be Bid**

Business Name : \_\_\_\_\_ Business Address : \_\_\_\_\_

Name of Contract/ Location	a. Owner Name b. Address c. Telephone Nos.	Nature of Work/ Kind of Goods	a. Amount of Contract b. Date Awarded	a. Contract Duration b. Date Completed
<u>Government</u>				
<u>Private</u>				

Note: This statement shall be supported with:

- 1 Notice of Award (if applicable)
- 2 Contract
- 3 Notice to Proceed (if applicable)
- 4 Sales Invoice/s, Delivery Receipt/s, and/or Certificate of Completion and Acceptance

Submitted by : \_\_\_\_\_  
(Printed Name & Signature)

Designation : \_\_\_\_\_

Signed : \_\_\_\_\_

Date : \_\_\_\_\_



Republic of the Philippines



Government Procurement Policy Board